

Model

Horizon Series™ HPF104-ADA Undercounter Plasma Freezer

Specifications

Application, Rating and Electrical Data

Application	Storage of blood and other medical and scientific products
Storage Volume	4 cu ft (113 L)
Storage Capacity	44 (plasma boxes)
Temperature Range	-15° to -30°C
Electrical Power	115V 60Hz
Maximum Current	5.75 FLA
Building Supply Rating	15 amp dedicated ground circuit
Power Plug / Power Cord Length	NEMA 5-15 hospital grade plug (115V) 8-10 ft (2439-3048 mm)
Certification / Agency Listing	QPS (Certified to UL and CSA Standards)
Indoor/Outdoor Use	Indoor use only
Application Environment	Non-corrosive, non-flammable, non-explosive, 15°C to 32°C (59°F to 90°F)

Refrigeration System

Refrigeration System	Forced-air circulation
Compressor / Number	.33 HP hermetic / 1
Condenser Type / Number	Air-cooled fin and tube / 1
Expansion Device	TXV valve
Evaporator Type	Air-cooled fin and tube
Defrost Method	Automatic, programmable
Refrigerant Charge	R404A Non-CFC

Performance Data

Uniformity	+/-2°C at -30°C Setpoint
------------	--------------------------

Warranty

Standard (US/Canada)	3 years compressor, 2 years parts, 1 year labor
Outside US/Canada	Consult your local representative

Controller

Interface	LED digital display, °C or °F
Power Switch	On/Off
Controller Type	Microprocessor-based controller with alarm / monitor
Security	Lockable door, optional keypad access
Control Sensor	RTD
High / Low Alarms	Fully adjustable
Door Ajar Alarm	Yes
Power Failure Alarm	Yes
Min/Max Display and Reset	Yes
Battery Back-up	9-volt non-rechargeable

Dimensions and Construction

Interior (w x h x d)	19.5 x 17.75 x 22 in 496 x 451 x 559 mm
Exterior (w x h x d) (Includes leveling feet)	24 x 32 x 26.75 in 610 x 813 x 680 mm
Overall Exterior (w x h x d) (Includes door handle and leveling feet)	24 x 32 x 28.5 in 610 x 813 x 724 mm
ADA Compatible	Fits under 34" (864 mm) ADA compliant counters
Insulation	Sustainable, U.S. EPA and SNAP approved Ecomate®
Exterior / Interior Finish	Bacteria-resistant powder coating
Doors	1, Solid
Access Ports	Rear access port
Perimeter Heater	Mullion Electric Heater
Interior Storage / Capacity	2 stainless steel drawers 16.75 x 17 in (426 x 432 mm) 100 lb (46 kg) max capacity / drawer
Leveling Feet	Standard
Casters	Optional / swivel locking
Integrated Access Control	Optional - Electromagnetic lock via digital keypad
Net Weight	211 lb (96 kg)
Shipping Weight	277 lb (126 kg)
Clearance Requirements	Minimum of 3" (76mm) behind unit for clearance and feature access.
Options / Accessories	Stacking Kit, Floor & Wall Bracket Kit, Remote Alarms, Casters, Stainless Steel Interior and Exterior, Remote Lock Adapter Kit, Extended Warranty



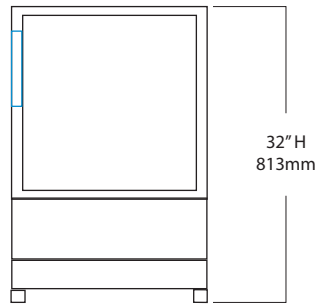

Note: Height with optional casters
33.5 in (851 mm)

