



Helmer Scientific, Noblesville, Indiana  
www.helmerinc.com

Technical Data Sheet  
High-Performance, Medical-grade Freezer  
Model: HLF105-GX, Horizon Series™ Laboratory / Undercounter

Application, Rating, & Electrical Data	
Application	High-performance storage of medical and scientific products
Storage Volume	5.3 cu ft (150 L)
Temperature Range	-15° to -30°C
Set-Point	-30°C
Electrical Power	115V 60Hz   220-240V 50/60Hz
Maximum Current	4.1A   2.0A
Facility Supply Rating	Branch circuit with earth ground, meeting plug/cord ratings as well as local electrical safety codes and requirements 110-120V AC: 15 A (minimum) 220-240V AC: 10 A (minimum)
Power Plug/Power Cord Length	NEMA 5-15 hospital-grade   115V 60Hz, 8 to 10 ft (2.4-3.0m) Inquire about additional plug/cord options
Certification/Agency Listing	QPS (Certified to UL and CSA Standards) IEC/UL61010-2-011:2016   IEC 61010-1:2010, AMD1:2016
ADA Compliant	Yes, fits under standard ADA compliant countertop
Indoor/Outdoor Use	Indoor use only, non-residential
Application Environment	Non-corrosive, non-flammable, non-explosive
Ambient Operating Temperature	+15°C to +32°C   +59°F to +90°F
Refrigeration	
Refrigeration System	VCC compressor-based, forced-air hydrocarbon
Compressor	Hermetic, variable speed (VCC). Rated speed range: 1600-4000 rpm
Condenser Type	Air-cooled fin and tube, sealed
Expansion Device	Cap tube
Evaporator Type	Direct expansion with forced-air fin and tube
Defrost Method	Automatic
Refrigerant	R290, Propane, EPA SNAP compliant
Controller / Configuration Settings	
User Interface	LED digital display, °C or °F
Power Switch	On/Off
Controller Type	Microprocessor with alarm/monitor
Security	Lockable door, PIN access via optional access control
Control Sensor	RTD, stainless steel
Communication Port	Remote alarm contacts
Power Failure Alarm	Yes
High/Low Alarms	Yes, fully adjustable
Door Ajar Alarm	Yes
Min/Max Temperature	Yes, display and reset
Temperature Monitoring	Yes, 4 oz bottle with screw cap
Battery Back-up	Yes, 9 volt, non-rechargeable, lithium

Performance Characteristics (normal operating conditions)	
Uniformity   °C	+/-2.0
Recovery to -29.5°C after 1 min door opening   min	23
Stability   °C	8.1
Energy consumption   kWh/day	4.82
Noise emission   dB	46
Heat rejection   BTU/hr	1701
Pull-down time to -30°C   min	70

All performance data from 5 cu ft freezer, 25°C ambient, -30.0°C

Dimensions and Construction	
Interior (w x h x d)	19.5 x 19.9 x 22.8 in   496 x 505 x 580 mm
Exterior (w x h x d)	24 x 31.5 x 26.7 in   610 x 798 x 678 mm *Add 2.5" to the height if choosing optional casters.
Overall Exterior (w x h x d)	24.3 x 31.9 x 28.4 in   617 x 809 x 721 mm *Add 0.3" to width if choosing optional access control *Includes leveling feet, door handle, user interface, and access panels.
Insulation	Sustainable, US EPA, and SNAP approved foam
Exterior/Interior Finish	Bacteria-resistant powder-coating
Door	Solid, field-reversible
Access Port	Rear Access Port- for external monitoring probe(s) (0.75 in   19 mm diameter)
Interior Storage (w x d)	2 ventilated, powder coated shelves, adjustable 17.9 x 21.3 in   454 x 541mm, 100 lb   46 kg max capacity/shelf
Leveling Feet	Yes, adjustable
Integrated Access Control	Optional - electromagnetic-lock with PIN entry via keypad
Net Weight	179 lb   82 kg
Shipping Weight	240 lb   110 kg
Clearance Requirements	Minimum 3" (76 mm) behind unit for for plug/cord and feature access Front ventilation eliminates the need for top or side clearance
Options   Accessories	Integrated access control, Stainless steel exterior/interior, Chart recorder, Chart paper, Swivel/Locking casters, Remote alarms, Remote lock adapter kit, Floor and Wall bracket kit, Stacking kit, Pedestal, Ventilated drawer, Storage trays, Left-hinge door, Certificate of Calibration, Temperature validation, Validation guide (IQ/OQ), Extended warranty
Warranty	Reli™ Warranty- 3 years compressor, 2 years parts, 1 year labor Outside US and Canada- Contact your distributor for warranty information

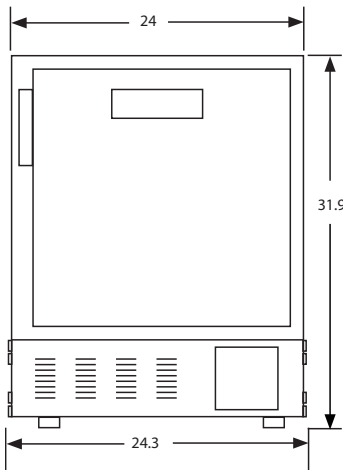

FRONT VIEW

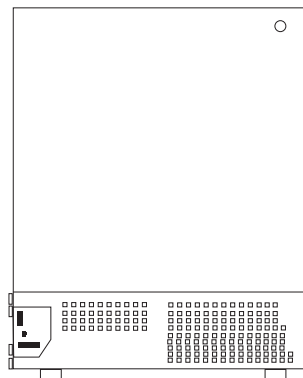

BACK VIEW

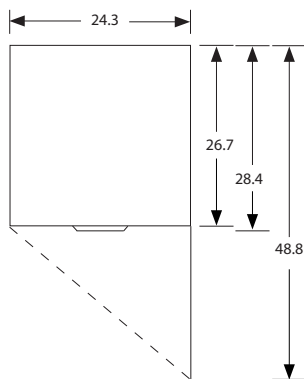

TOP VIEW

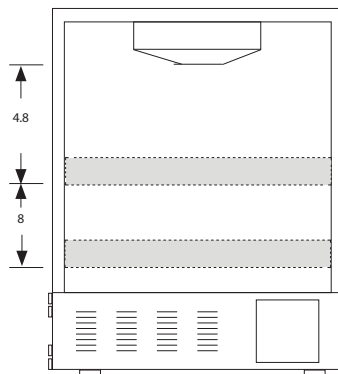

INTERIOR VERTICAL SPACING