

Model

Horizon Series™ HPR456 Pass-Thru Refrigerator

Specifications

Application, Rating and Electrical Data

Application	Storage of medical and scientific products
Storage Volume	58 cu ft (1642 L)
Temperature Range	2° to 10°C
Electrical Power	115V 60Hz 230V 50Hz 230V 60Hz
Maximum Current	13.25 FLA / 7.8 FLA / 8.2 FLA
Building Supply Rating	15 amp dedicated ground circuit
Power Plug / Power Cord Length	NEMA 5-15 hospital grade plug (115V) CEE 7/7 plug (230V 50Hz) NEMA 6-15 hospital grade plug (230V 60Hz) 8-10 ft (2439-3048 mm)
Certification / Agency Listing	QPS (Certified to UL and CSA Standards)
Indoor/Outdoor Use	Indoor use only
Application Environment	Non-corrosive, non-flammable, non-explosive, 15°C to 32°C (59°F to 90°F)

Refrigeration System

Refrigeration System	Forced-air circulation
Compressor / Number	.5 HP hermetic / 1
Condenser Type / Number	Air-cooled fin and tube / 1
Expansion Device	Cap tube
Evaporator Type	Air-cooled fin and tube
Defrost Method	Automatic
Refrigerant Charge	R134A Non-CFC

Performance Data

Uniformity	+/-1°C at 4°C Setpoint
------------	------------------------

Warranty

Rel.i™ (US/Canada)	5 years compressor, 2 years parts, 1 year labor
Outside US/Canada	Consult your local representative

Controller

Interface	LED digital display, °C or °F
Power Switch	On/Off - All Circuit breaker - 230V only
Controller Type	Microprocessor-based controller with alarm/ monitor
Security	Lockable door
Control Sensor	RTD
High / Low Alarms	Fully adjustable
Door Ajar Alarm	Yes
Power Failure Alarm	Yes
Min/Max Display and Reset	Yes
Battery Back-up	9-volt non-rechargeable

Dimensions and Construction

Interior (w x h x d)	55 x 58.25 x 32 in 1397 x 1480 x 813 mm
Exterior (w x h x d)	59.25 x 80 x 36 in 1505 x 2032 x 915 mm
Overall Exterior (w x h x d) (Includes door handles)	59.25 x 80 x 40 in 1505 x 2032 x 1016 mm
Insulation	Minimum of 2" (51mm) non-CFC foamed urethane insulation
Exterior / Interior Finish	Bacteria-resistant powder coating
Doors	4, Dual-pane glass
Access Ports	Top for external monitoring probe(s)
Interior Storage / Capacity	6 epoxy coated shelves 22 x 29 in (559 x 737 mm) 6 stainless steel drawers 22 x 27 in (559 x 686 mm) 100 lb (46 kg) max capacity / shelf or drawer
Lighting	Adjustable LED on/off switch
Casters	Standard / swivel locking
Net Weight	786 lbs (357 kg)
Shipping Weight	922 lbs (419 kg)
Clearance Requirements	Minimum of 8" (203mm) above the control side of the refrigerator. Clearance above the clean room side may be 0". Top enclosure cannot be placed more than 11" (280mm) from the front (clean room side) of the refrigerator.
Options / Accessories	Chart Recorder, Skirt, Finish Trim Kit, Remote Alarms, Floor Bracket Kit, Stainless Steel Interior, Extended Warranty



Technical Data Sheet

Pharmacy Pass-Thru Refrigerator

Horizon Series™ HPR456

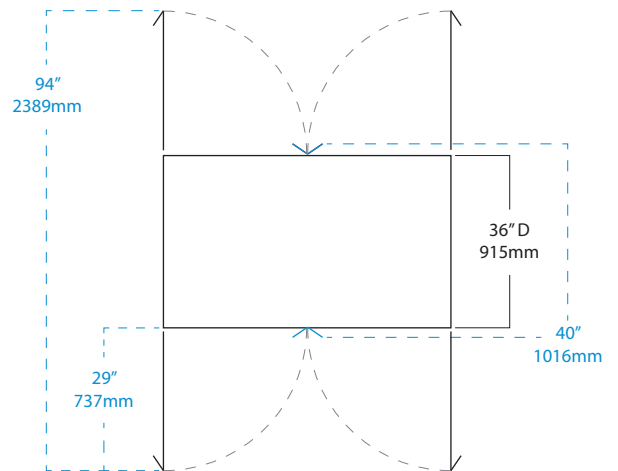
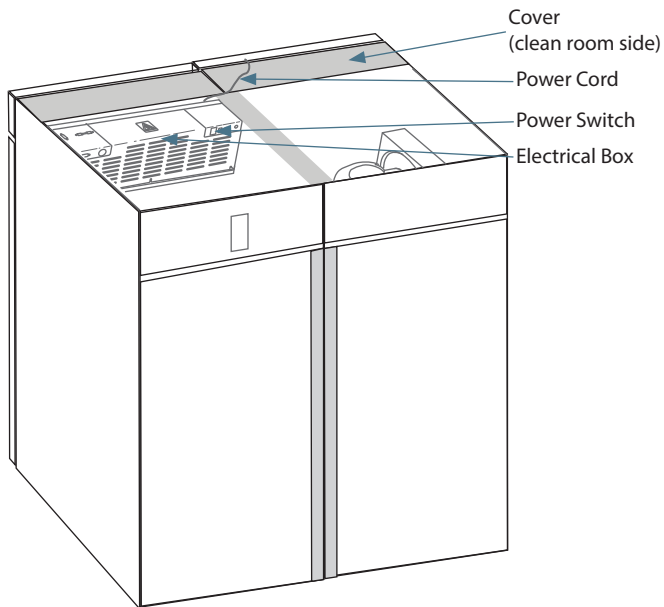
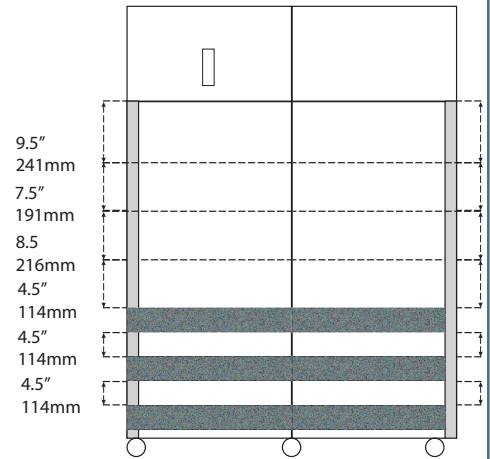
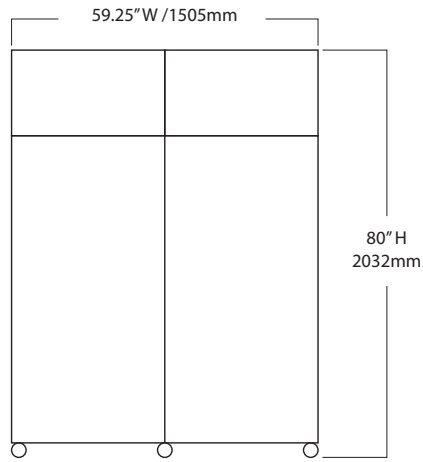

Helmer Scientific | 14400 Bergen Boulevard | Noblesville, IN 46060 | USA
 +1.317.773.9073 | www.helmerinc.com



© 2016-2020 Helmer Inc. All rights reserved. 380341-1/G 9/20
 All trademarks are the property of Helmer Scientific. Specifications subject to change.