

Model

i.Series® iLR120 Upright Laboratory Refrigerator

Specifications

Application, Rating and Electrical Data		Controller	
Application	Storage of medical and scientific products	Interface	i.C ³ ® eye-level, color touchscreen
Storage Volume	20.2 cu ft (572 L)	Power Switch	On/Off - All Circuit breaker - 230V only
Temperature Range	2° to 10°C	Controller Type	Microprocessor with touchscreen input and display. Includes USB port for data retrieval.
Electrical Power	115V 60Hz 230V 50Hz 230V 60Hz	Security	Lockable door, password protected settings, optional PIN access
Maximum Current	7.5 FLA / 4.2 FLA / 4.2 FLA	Control Sensor	RTD
Building Supply Rating	15 amp dedicated ground circuit	Communication Ports	(2) USB Ports (1) RJ45 Hub (1) RS232 Port (optional)
Power Plug / Power Cord Length	NEMA 5-15 hospital grade plug (115V) CEE 7/7 plug (230V 50Hz) NEMA 6-15 hospital grade plug (230V 60Hz) 8-10 ft (2439-3048 mm)	High / Low Alarms	Fully adjustable
Certification / Agency Listing	QPS (Certified to UL and CSA Standards) ENERGY STAR® Certified	High / Low Alarm Test	Automatic (Peltier)
Indoor/Outdoor Use	Indoor use only	Door Ajar Alarm	Fully adjustable
Application Environment	Non-corrosive, non-flammable, non-explosive, 15°C to 32°C (59°F to 90°F)	Power Failure Alarm	Yes
Refrigeration System		Condenser Temperature Alarm	Fully adjustable
Refrigeration System	Forced-air circulation	Event Log	All alarms, door openings, download via USB
Compressor / Number	.33 HP hermetic / 1	Temperature Log	60 days, download via USB
Condenser Type / Number	Air-cooled fin and tube / 1	Access Log	60 days, download via USB
Expansion Device	Cap tube	Interactive Temperature Graph	Yes
Evaporator Type	Air-cooled fin and tube	Min/Max Display and Reset	Yes
Defrost Method	Automatic	Battery Back-up	20 hour display and alarm battery back-up for i.C ³ ® touchscreen (rechargeable 12V, lead acid battery)
Refrigerant Charge	R134A Non-CFC	Dimensions and Construction	
Performance Data		Interior (w x h x d)	24.75 x 58.25 x 24.25 in 629 x 1480 x 616 mm
Uniformity	+/-1°C at 4°C Setpoint	Exterior (w x h x d)	29.5 x 79.5 x 29.5 in 750 x 2020 x 750 mm
Warranty		Overall Exterior (w x h x d) (Includes door handle, electrical panel, and evaporation tray)	29.5 x 79.5 x 32.5 in 750 x 2020 x 826 mm
Rel.i™ Plus (US/Canada)	7 years compressor, 2 years parts, 1 year labor	Insulation	Minimum of 2" (51mm) non-CFC foamed urethane insulation
Outside US/Canada	Consult your local representative	Exterior / Interior Finish	Bacteria-resistant powder coating
		Doors	1, Dual-pane glass
		Access Ports	Sidewall with interior and exterior plugs Top for external monitoring probe(s)
		Interior Storage / Capacity	4 epoxy coated shelves 22 x 23 in (559 x 585 mm) 100 lb (46 kg) max capacity / shelf
		Lighting	Adjustable LED Auto-on, on/off switch
		Casters	Standard / swivel locking
		Integrated Access Control	Optional - Electromagnetic lock via i.C ³ User Interface PIN
		Net Weight	473 lb (215 kg)
		Shipping Weight	563 lb (256 kg)
		Clearance Requirements	Minimum of 8" (203mm) above and 3" (76mm) behind unit.
		Options / Accessories	Chart Recorder, Floor & Wall Bracket Kit, Remote Alarms, Leveling Feet, Stainless Steel Interior, Remote Lock Adapter Kit, Extended Warranty



Technical Data Sheet

Laboratory Refrigerator

i.Series® iLR120

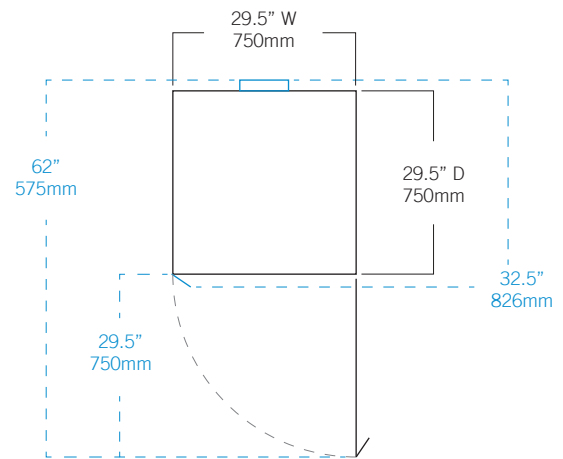
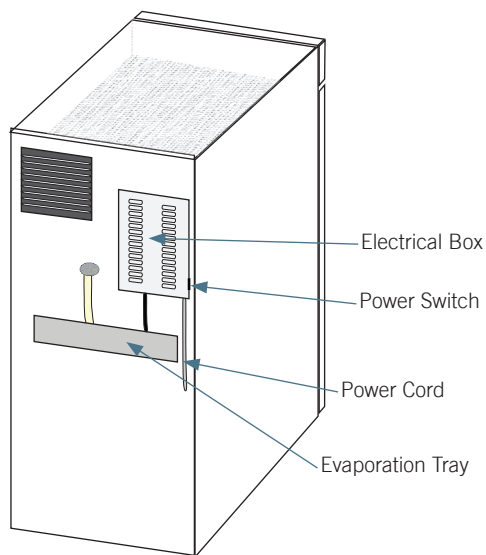
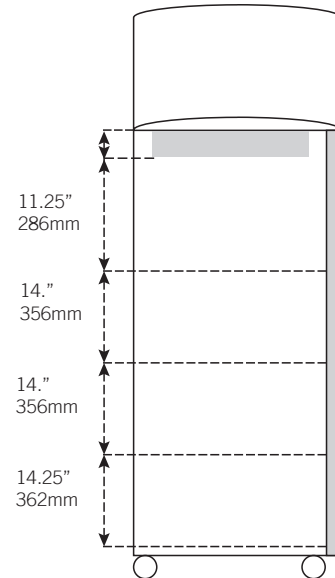
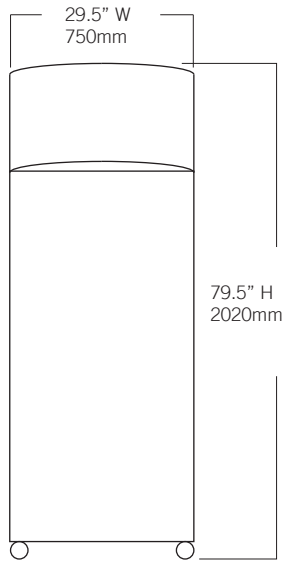

Helmer Scientific | 14400 Bergen Boulevard | Noblesville, IN 46060 | USA
+1.317.773.9073 | www.helmerinc.com



© 2016 Helmer Inc. All rights reserved. 380315-1/F 10/17
All trademarks are the property of Helmer Scientific. Specifications subject to change.