

Model

Horizon Series™ HLR120 Upright Laboratory Refrigerator

Specifications

Application, Rating and Electrical Data		Controller	
Application	Storage of medical and scientific products	Interface	LED digital display, °C or °F
Storage Volume	20.2 cu ft (572 L)	Power Switch	On/Off - All Circuit breaker - 230V only
Temperature Range	2° to 10°C	Controller Type	Microprocessor-based controller with alarm/ monitor
Electrical Power	115V 60Hz 230V 50Hz 230V 60Hz	Security	Lockable door, optional keypad access
Maximum Current	7.5 FLA / 4.2 FLA / 4.2 FLA	Control Sensor	RTD
Building Supply Rating	15 amp dedicated ground circuit	High / Low Alarms	Fully adjustable
Power Plug / Power Cord Length	NEMA 5-15 hospital grade plug (115V) CEE 7/7 plug (230V 50Hz) NEMA 6-15 hospital grade plug (230V 60Hz) 8-10 ft (2439-3048 mm)	Door Ajar Alarm	Yes
Certification / Agency Listing	QPS (Certified to UL and CSA Standards) ENERGY STAR® Certified	Power Failure Alarm	Yes
Indoor/Outdoor Use	Indoor use only	Min/Max Display and Reset	Yes
Application Environment	Non-corrosive, non-flammable, non-explosive, 15°C to 32°C (59°F to 90°F)	Battery Back-up	9-volt non-rechargeable
Refrigeration System		Dimensions and Construction	
Refrigeration System	Forced-air circulation	Interior (w x h x d)	24.75 x 58.25 x 24.25 in 629 x 1480 x 616 mm
Compressor / Number	.33 HP hermetic / 1	Exterior (w x h x d)	29.5 x 78.75 x 29.5 in 750 x 2001 x 750 mm
Condenser Type / Number	Air-cooled fin and tube / 1	Overall Exterior (w x h x d) (Includes door handle, electrical panel, and evaporation tray)	29.5 x 78.75 x 32.5 in 750 x 2001 x 826 mm
Expansion Device	Cap tube	Insulation	Minimum of 2" (51mm) non-CFC foamed urethane insulation
Evaporator Type	Air-cooled fin and tube	Exterior / Interior Finish	Bacteria-resistant powder coating
Defrost Method	Automatic	Doors	1, Dual-pane glass
Refrigerant Charge	R134A Non-CFC	Access Ports	Sidewall with interior and exterior plugs Top for external monitoring probe(s)
Performance Data		Interior Storage / Capacity	4 epoxy coated shelves 22 x 23 in (559 x 585 mm) 100 lb (46 kg) max capacity / shelf
Uniformity	+/-1°C at 4°C Setpoint	Lighting	Adjustable LED on/off switch
Warranty		Casters	Standard / swivel locking
Rel.i™ (US/Canada)	5 years compressor, 2 years parts, 1 year labor	Integrated Access Control	Optional - Electromagnetic lock via digital keypad
Outside US/Canada	Consult your local representative	Net Weight	470 lb (214 kg)
		Shipping Weight	563 lb (256 kg)
		Clearance Requirements	Minimum of 8" (203mm) above and 3" (76mm) behind unit.
		Options / Accessories	Chart Recorder, Floor & Wall Bracket Kit, Remote Alarms, Leveling Feet, Stainless Steel Interior, Remote Lock Adapter Kit, Extended Warranty



Technical Data Sheet

Laboratory Refrigerator

Horizon Series™ HLR120

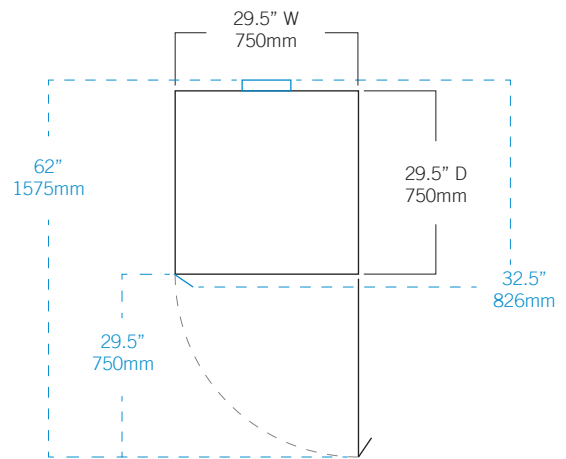
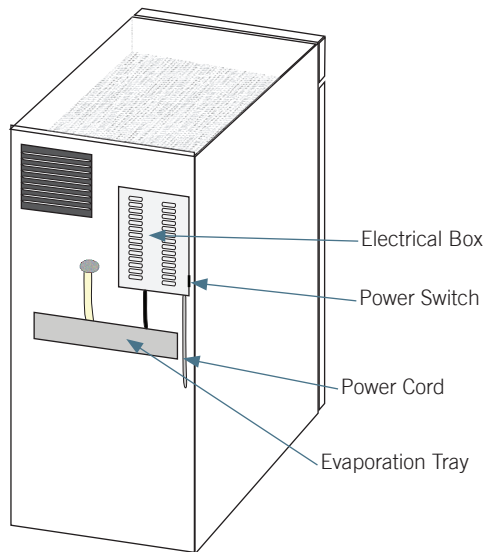
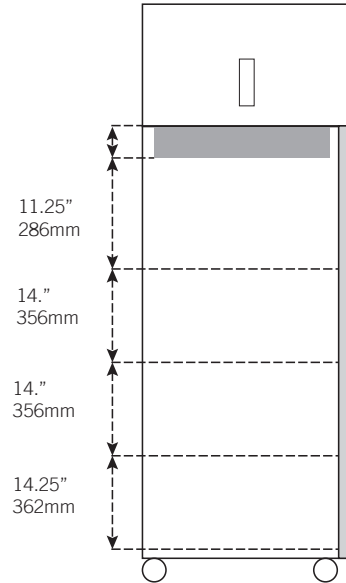
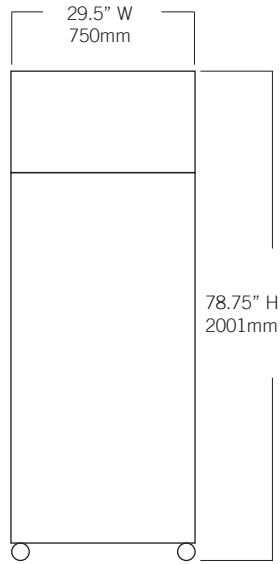

Helmer Scientific | 14400 Bergen Boulevard | Noblesville, IN 46060 | USA
+1.317.773.9073 | www.helmerinc.com



© 2015 Helmer Inc. All rights reserved. 380322-1/F 10/17
All trademarks are the property of Helmer Scientific. Specifications subject to change.