

# Remote Access Control

For Helmer Scientific Products with Access Control

Control integrated exterior door locks on Helmer equipment with your existing 3rd party device



Possible Customer-provided Access Management Devices



Retina Scan

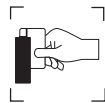

Magnetic Card  
Swipe



Manual Keypad



RFID Badge  
Reader



Fingerprint Scan

## Remote Access Control Functionality

Limited solutions exist that allow a facility to use a third-party access system to manage access to temperature-controlled cold storage units. Helmer Scientific has developed a custom integration that allows third-party independent user validation (devices) to control the integrated door lock on a Helmer refrigerator or freezer (-30° or -80°C), or on a Pro Line platelet incubator.

Using your current access system to securely access your Helmer product offers convenience and added security. Remote Access Control is an ideal solution for simple access control

or your most difficult workflow. In addition, it reduces foot traffic and noise in your work space, while still allowing for quick and easy access to cold storage.

The Remote Access Control integration is offered through Helmer Scientific Custom Products Division and is available for Blood Bank, Laboratory, and Pharmacy refrigerators and freezers from 5 to 58 cu ft., as well as Ultra-low freezers and platelet incubators. All models must be configured with Access Control locking doors.

## Functionality

Integrations can be implemented via a hard wire connection by cable to access system.

Designed to interface with customer access control system that utilizes programmable dry contacts located up to 100 yards away.

Contact Helmer for additional technical details

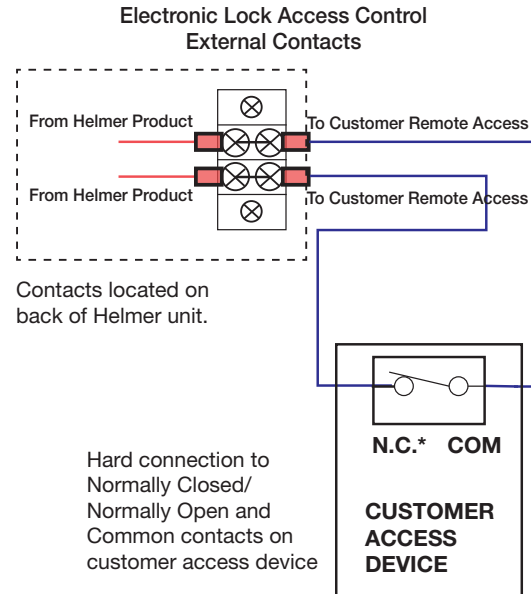

## Specifications

- Compatible third-party Access Management Devices must have programmable dry contacts
- Helmer Scientific product provides 12-15 volt power output to programmable customer access device contacts to control the electronic lock on Helmer device
- Helmer devices configured with Remote Access Control will include a 2-position terminal strip as the connection point for the third-party Access Management System
- Access Management System requires 18 gauge or heavier wire no more than 100 yards away from the Helmer product
- Helmer devices may be Helmer factory configured for redundant method of operator access (i.e. keypad may remain functional)
- Contact Helmer Technical Services for Pro Line Platelet Storage remote access applications

