

Refrigerator Service Manual

i.Series® and Horizon Series™



Model Group	i.Series	Horizon Series
Blood Bank	iB111 (Version A) iB120, iB125, iB245, iB256 (Versions A and B) iHB111 (Version B) iHB120, iHB125, iHB245, iHB256 (Versions A and B)	HB111 (Version A) HB120, HB125, HB245, HB256 (Versions A and B) HHB111 (Version A) HHB120, HHB125, HHB245, HHB256 (Versions A and B)
Laboratory	iLR111 (Version A) iLR120, iLR125, iLR245, iLR256 (Versions A and B)	HLR111 (Version A) HLR120, HLR125, HLR245, HLR256 (Versions A and B)
Pharmacy	iPR111 (Version A) iPR120, iPR125, iPR245, iPR256 (Versions A and B)	HPR111 (Version A) HPR120, HPR125, HPR245, HPR256 (Versions A and B)

HELMER SCIENTIFIC
14400 Bergen Boulevard
Noblesville, IN 46060 USA



PH +1.317.773.9073
FAX +1.317.773.9082
USA and Canada 800.743.5637



Document History

Revision	Date	CO	Supersession	Revision Description
O	01 APR 2014*	9313	O supersedes A, B, C, D, E, F, G, H, I, J, K, L, M, N	Revised layout for ease of navigation and locating information.

* Date submitted for Change Order review. Actual release date may vary.

Contents

Section I: General Information	8
1 About this Manual	8
1.1 Intended Audience	8
1.2 Model References	8
1.3 Copyright and Trademark	8
2 Safety	8
2.1 Safety Definitions	8
2.2 Product Labels	9
2.3 Avoiding Injury	9
3 Configuration	10
3.1 Model and Input Power	10
3.2 Control System	10
3.2.1 i.Series Monitoring System and Independent Temperature Controller	11
3.2.2 Horizon Series Blood Bank Monitoring System and Independent Temperature Controller	11
3.2.3 Horizon Series Laboratory Monitoring and Control System	12
3.3 Temperature Probes	12
3.3.1 Fill Temperature Probe Bottle	13
3.3.2 Install Additional Probe Through Top Port	13
3.3.3 Install Additional Probe Through Side Port	13
3.4 Internal Outlet	13
3.5 Chart Recorder	13
3.5.1 Chart Recorder Access	14
3.5.2 Install Chart Paper	14
4 Alarm Reference	15
5 Compliance	15
5.1 Regulatory Compliance	15
5.2 WEEE Compliance	15
6 Warranty	16
6.1 Rel.i™ Product Warranty USA and Canada	16
6.1.1 Rapid Resolution	16
6.1.2 Compressor	16
6.1.3 Parts	16
6.1.4 Labor	16
6.1.5 Additional Warranty Information	16
6.2 Outside of USA and Canada	17
Section II: i.Series® - All Models	18
7 Product Configuration	18
7.1 Install Battery for Backup Power	18
7.2 External Monitoring Devices	19
7.2.1 Connect to Remote Alarm Interface	19
7.3 Move Drawers, Shelves, and Baskets	20
7.4 Drawer Labels	21
7.5 Move Slides and Brackets	21
7.6 Optional Adapter Kits for Medication Dispensing Locks	21

8	Temperature Monitor Settings	22
8.1	Home Screen	22
8.1.1	Home Screen Functions	22
8.2	Main Screen	23
8.3	Temperature Graph	24
8.3.1	Enable or Disable the Temperature Graph	24
8.4	Change Configuration Password	25
8.5	Calibrate Chamber Temperature Probe	25
8.6	Factory Default Settings	26
8.7	Restore Factory Default Settings	26
8.8	Alarm Settings	27
8.8.1	Alarm Volume	27
8.8.2	Alarm Pulse	27
8.8.3	High Chamber Temperature Alarm	27
8.8.4	Low Chamber Temperature Alarm	28
8.8.5	Condenser Temperature Alarm	28
8.8.6	Door Ajar Alarm	28
8.8.7	Power Failure Alarm	29
8.8.8	Chart Paper Alarm	29
8.9	Test Alarms	30
8.9.1	Automatic Chamber Temperature Alarm Test	30
8.9.2	Manual Chamber Alarm Test	31
8.9.3	Power Failure Alarm Test	32
8.9.4	Door Ajar Alarm Test	32
8.9.5	No Battery Alarm Test	32
8.10	Additional System Settings	33
8.10.1	Screen Contrast	33
8.10.2	Date and Time	33
8.10.3	Display Language	33
8.10.4	Temperature Units	34
8.11	Event Log	35
8.11.1	Event Details	36
8.12	Upgrade System Firmware	36
8.13	Reset the i.Center Monitoring System	36
8.14	View Manufacturer and Product Information	37
9	Temperature Controller Setpoints	37
9.1	Level 1 Parameters and Values	38
9.2	Level 2 Parameters and Values	39
9.3	Level 3 Parameters and Values	39
9.4	Level 4 Parameters and Values	40
9.5	Change the Refrigerator Setpoint	40
9.6	Change the Hysteresis Value	41
10	Maintenance	41
10.1	Recharge Refrigerant	41
10.2	Test Monitoring System Backup Batteries	42
10.3	Replace Monitoring System Backup Batteries	42
10.4	Replace the Fluorescent Lamps	42

10.5	Clean the Refrigerator	42
10.5.1	Condenser Grill	42
10.5.2	Exterior	42
10.5.3	Interior	43
10.5.4	Door Gaskets	43
10.6	Unit Cooler Cover Removal and Installation	44
10.6.1	Remove the Unit Cooler Cover	44
10.6.2	Install the Unit Cooler Cover	45
10.7	Supplies.	45
11	Troubleshooting	46
11.1	General Operation Problems	46
11.2	Chamber Temperature Problems	47
11.3	Alarm Activation Problems	48
11.4	Testing Problems.	51
11.5	Condensation Problems	51
12	Parts	52
12.1	Front	52
12.1.1	Display	53
12.2	Top.	54
12.3	Rear.	55
12.3.1	Electrical Box	56
12.4	Interior.	57
12.4.1	Lighting.	58
12.4.2	Unit Cooler	59
12.4.3	Storage.	60
12.4.4	Door and Hinge	61
13	Schematics	62
13.1	iB and iHB Models; 11, 20, 25, 45, 56 Cubic Feet.	62
13.2	iLR, iPR Models; 11 Cubic Feet	63
13.3	iLR and iPR Models; 20, 25, 45, and 56 Cubic Feet.	64
14	i.Center Screen Reference	65
Section III: Horizon Series™ - Blood Bank Models		67
15	Product Configuration	67
15.1	Install Battery for Backup Power	67
15.2	External Monitoring Devices	68
15.2.1	Connect to Remote Alarm Interface	68
15.3	Move Drawers, Shelves, and Baskets.	69
15.4	Move Slides and Brackets.	70
15.5	Optional Adapter Kits for Medication Dispensing Locks	70
16	Temperature Monitor Settings	70
16.1	Home Screen	70
16.1.1	Home Screen Functions.	71
16.2	Main Screen	71
16.3	Change Configuration Password.	72
16.4	Calibrate Chamber Temperature Probe	72
16.5	Factory Default Settings	73
16.6	Restore Factory Default Settings	73

16.7 Alarm Settings	74
16.7.1 Alarm Volume	74
16.7.2 Alarm Pulse	74
16.7.3 High Chamber Temperature Alarm	74
16.7.4 Low Chamber Temperature Alarm	75
16.7.5 Door Ajar Alarm	75
16.7.6 Power Failure Alarm	75
16.7.7 Chart Paper Alarm	76
16.8 Test Alarms	77
16.8.1 Manual Chamber Alarm Test	77
16.8.2 Power Failure Alarm Test	78
16.8.3 Door Ajar Alarm Test	78
16.9 Additional System Settings	79
16.9.1 Screen Contrast	79
16.9.2 Date and Time	79
16.9.3 Display Language	79
16.9.4 Temperature Units	80
16.10 Upgrade System Firmware	80
16.11 Reset the Horizon Series Monitoring System	80
16.12 View Manufacturer and Product Information	80
17 Temperature Controller Setpoints	81
17.1 Level 1 Parameters and Values	82
17.2 Level 2 Parameters and Values	83
17.3 Level 3 Parameters and Values	83
17.4 Level 4 Parameters and Values	84
17.5 Change the Refrigerator Setpoint	84
17.6 Change the Hysteresis Value	85
18 Maintenance	85
18.1 Recharge Refrigerant	85
18.2 Test Monitoring System Backup Batteries	86
18.3 Replace the Fluorescent Lamps	86
18.4 Clean the Refrigerator	86
18.4.1 Condenser Grill	86
18.4.2 Exterior	86
18.4.3 Interior	86
18.4.4 Door Gaskets	86
18.5 Unit Cooler Cover Removal and Installation	87
18.5.1 Remove the Unit Cooler Cover	88
18.5.2 Install the Unit Cooler Cover	88
18.6 Supplies	88
19 Troubleshooting	89
19.1 General Operation Problems	89
19.2 Chamber Temperature Problems	90
19.3 Alarm Activation Problems	91
19.4 Condensation Problems	93
20 Parts	94
20.1 Front	94
20.1.1 Horizon Display	95
20.2 Top	96

20.3	Rear	97
20.3.1	Electrical Box	98
20.4	Interior	99
20.4.1	Lighting	100
20.4.2	Unit Cooler	100
20.4.3	Storage	101
20.4.4	Door and Hinge	102
21	Schematics	103
21.1	HB Models; 11, 20, 25, 45, 56 Cubic Feet	103
22	Horizon Series Screen Reference	104
Section IV: Horizon Series™ - Laboratory, Pharmacy, and International Blood Bank Models		
23	Product Configuration	106
23.1	Install Battery for Backup Power	106
23.2	External Monitoring Devices	107
23.2.1	Connect to Remote Alarm Interface	107
23.3	Move Drawers, Shelves, and Baskets	108
23.4	Move Slides and Brackets	109
23.5	Optional Adapter Kits for Medication Dispensing Locks	109
24	Settings	109
24.1	Monitor and Controller Interface	110
24.2	Refrigerator Setpoint	111
24.3	Temperature Alarm Setpoints	111
24.3.1	High Temperature Alarm	112
24.3.2	Low Temperature Alarm	112
24.4	Temperature Calibration Setpoints	112
24.4.1	Monitor Offset	113
24.4.2	Control Sensor Offset	114
24.4.3	Hysteresis	114
24.5	Test Alarms	114
24.5.1	Chamber Temperature Alarm	114
24.5.2	Power Failure Alarm	115
24.5.3	Door Open Alarm	115
25	Maintenance	116
25.1	Recharge Refrigerant	116
25.2	Test Monitoring System Backup Batteries	117
25.3	Replace the Fluorescent Lamps	117
25.4	Clean the Refrigerator	117
25.4.1	Condenser Grill	117
25.4.2	Exterior	117
25.4.3	Interior	117
25.4.4	Door Gaskets	117
25.6	Unit Cooler Cover Removal and Installation	118
25.6.1	Remove the Unit Cooler Cover	119
25.6.2	Install the Unit Cooler Cover	119
25.7	Supplies	119

26 Troubleshooting	120
26.1 General Operation Problems	120
26.2 Chamber Temperature Problems	121
26.3 Alarm Activation Problems	122
26.4 Condensation Problems	124
27 Parts	125
27.1 Front	125
27.1.1 Laboratory Display	126
27.2 Top	126
27.3 Rear	127
27.3.1 Electrical Box	128
27.4 Interior	129
27.4.1 Lighting	130
27.4.2 Unit Cooler	130
27.4.3 Storage	131
27.4.4 Door and Hinge	132
28 Schematics	133
28.1 HLR and HPR Models; 11 Cubic Feet	133
28.2 HLR and HPR Models; 20, 25, 45, 56 Cubic Feet	134
28.3 HHB Models; 11, 20, 25, 45, 56 Cubic Feet	135

Section I: General Information

1 About this Manual

1.1 Intended Audience

This manual is intended for use by end users of the refrigerator and authorized service technicians.

1.2 Model References

Generic references are used throughout this manual to group models that contain similar features. For example, “125 models” refers to all models of that size (iB125, HB125, iHB125, HHB125, iLR125, HLR125, iPR125, HPR125). This manual covers all upright refrigerators, which may be identified singly, by their size, or by their respective “Series.”

1.3 Copyright and Trademark

Helmer®, i.Series®, i.Center®, Horizon Series™, and Rel.i™ are registered trademarks or trademarks of Helmer, Inc. in the United States of America. Copyright © 2014 Helmer, Inc. All other trademarks and registered trademarks are the property of their respective owners.

Helmer, Inc., doing business as (DBA) Helmer Scientific and Helmer.

2 Safety

The operator or technician performing maintenance or service on Helmer Scientific products must (a) inspect the product for abnormal wear and damage, (b) choose a repair procedure which will not endanger his/her safety, the safety of others, the product, or the safe operation of the product, and (c) fully inspect and test the product to ensure the maintenance or service has been performed properly.

2.1 Safety Definitions

The following general safety alerts appear with all safety statements within this manual. Read and abide by the safety statement that accompanies the safety alert symbol.



WARNING

The safety statement that follows this safety alert symbol indicates a hazardous situation which, if not avoided, could result in serious injury.



CAUTION

The safety statement that follows this safety alert symbol indicates a hazardous situation which, if not avoided, could result in minor or moderate injury.



NOTICE

The safety statement that follows this safety alert symbol indicates a situation which, if not avoided, could result in damage to the product or stored inventory.

2.2 Product Labels

Caution: Risk of damage to equipment or danger to operator



Caution: Hot surface



Caution: Shock/electrical hazard



Caution: Unlock all casters



Earth / ground terminal



Protective earth / ground terminal

2.3 Avoiding Injury

- ▶ Review safety instructions before installing, using, or maintaining the equipment.
- ▶ Before moving unit, ensure door(s) is closed and casters are unlocked and free of debris.
- ▶ Before moving unit, disconnect the AC power cord and secure the cord.
- ▶ Never physically restrict any moving component.
- ▶ Avoid removing electrical service panels and access panels unless so instructed.
- ▶ Keep hands away from pinch points when closing the door.
- ▶ Avoid sharp edges when working inside the electrical compartment and refrigeration compartment.
- ▶ Ensure biological materials are stored at recommended temperatures determined by standards, literature, or good laboratory practices.
- ▶ Proceed with caution when adding and removing samples from the refrigerator.
- ▶ Use supplied power cord only.
- ▶ Using the equipment in a manner not specified by Helmer Scientific may impair the protection provided by the equipment.
- ▶ Decontaminate parts prior to sending for service or repair. Contact Helmer Scientific or your distributor for decontamination instructions and a Return Authorization Number.
- ▶ Ensure biological materials are stored safely, in accordance with all applicable organizational, regulatory, and legal requirements.
- ▶ The refrigerator is not considered to be a storage cabinet for flammable or hazardous materials.

3 Configuration

3.1 Model and Input Power

NOTE Service information varies depending on the model and power requirements.

This information appears on the product specification label, located on the rear of the refrigerator. The model also appears on a label located in the chamber on the upper side of the right wall.

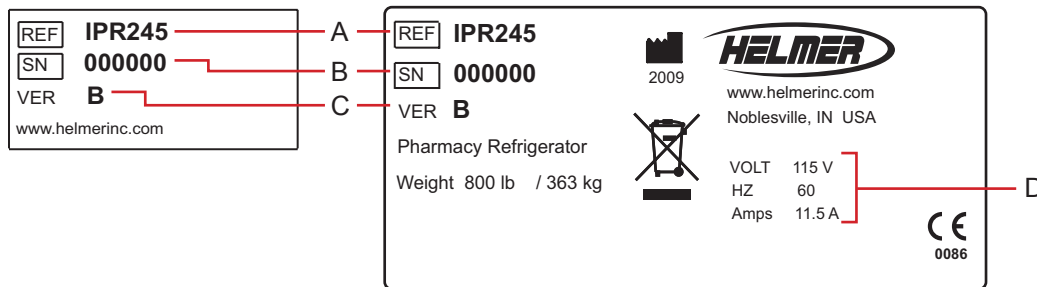

Left: Chamber label. Right: Product specification label (located on the rear at lower left).

Label	Description
A	Model (REF)
B	Serial number (SN)
C	Version
D	Power requirements

3.2 Control System

NOTE Service information varies depending on the control system.

Helmer refrigerators have one of three control systems installed. The type of control system varies by model.

3.2.1 i.Series Monitoring System and Independent Temperature Controller

NOTE This section applies to iB, iHB, iLR, and iPR models.

i.Series refrigerators are equipped with the i.Center monitoring system and independent temperature controller.

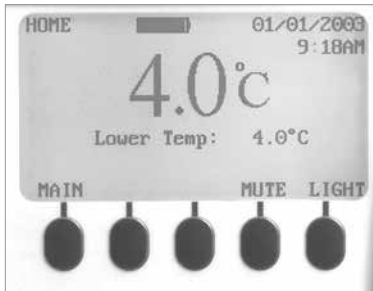

i.Center monitor.



Independent temperature controller.

3.2.2 Horizon Series Blood Bank Monitoring System and Independent Temperature Controller

Horizon Series blood bank refrigerators are equipped with the Horizon monitoring system and independent temperature controller.

NOTE This section applies to HB models.

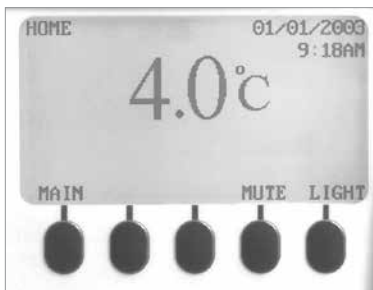

Horizon monitor.



Independent temperature controller.

3.2.3 Horizon Series Laboratory Monitoring and Control System

NOTE This section applies to HPR, HLR, and HHB models.

Horizon Series laboratory and pharmacy refrigerators, and international Horizon Series blood bank refrigerators are equipped with the laboratory monitor and temperature controller. The combined laboratory system controls chamber temperature and monitors and displays operational information.



Laboratory monitoring and control system.

3.3 Temperature Probes

Number and location of probes varies by model. External probes may be introduced through existing top port and immersed in existing probe bottle.

NOTE Probes may also be introduced through the side port (side port availability varies, depending on model).

For each probe bottle, use:

- ▶ Approximately 4 oz. (120 mL) of product simulation solution (10:1 ratio of water to glycerin).

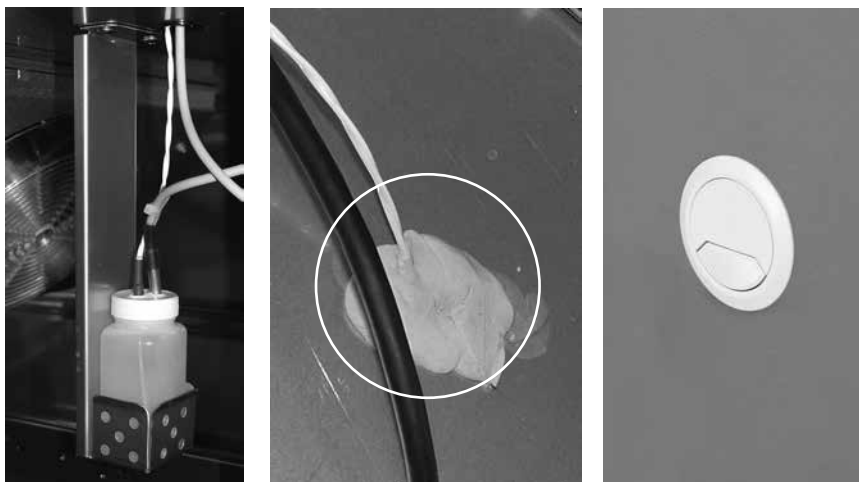

Left: Probe bottle with temperature probe. Center: Access port as seen from top of refrigerator. Right: Access port as seen from side of refrigerator.

3.3.1 Fill Temperature Probe Bottle



NOTICE Temperature probes are fragile; handle with care.

- 1 Remove all probes from bottle and remove bottle from bracket.
- 2 Remove cap and fill with approximately 4 oz. (120 mL) of product simulation solution.
- 3 Install cap and place bottle in bracket.
- 4 Replace probes, immersing at least 2" (50 mm) in solution.

3.3.2 Install Additional Probe Through Top Port

- 1 Peel back putty to expose port.
- 2 Insert probe through port into chamber.
- 3 Insert probe into bottle.
- 4 Replace putty, ensuring a tight seal.

3.3.3 Install Additional Probe Through Side Port

- 1 Remove the interior and exterior plugs to expose the side access port.
- 2 Insert probe through port into chamber.
- 3 Insert probe into bottle.
- 4 Replace plugs, ensuring a tight seal.

3.4 Internal Outlet

If installed, this duplex outlet, with vapor-proof cover and a GFCI (ground fault circuit interrupter), provides a power source for operating devices inside refrigerator.



Internal duplex outlet



CAUTION

- ▶ The internal outlet is rated for 115 V, 15 A. Do not plug any device into these outlets that exceeds this rating.
- ▶ Test the GFCI periodically to ensure proper, safe operation.

3.5 Chart Recorder

If installed, refer to the Temperature Chart Recorder Operation and Service Manual on CD.

The chart recorder has a battery system, enabling a period of continuous operation if power is lost. Battery life varies by manufacturer as well as voltage level remaining. Providing full power is available, backup power for the temperature chart recorder is available for up to 14 hours.

Prior to use:

- ▶ Connect the chart recorder to AC power.
- ▶ Install battery.
- ▶ Add paper.
- ▶ Install the chart recorder probe in the probe bottle, through the top port.
- ▶ Calibrate chart recorder to match chamber temperature.

3.5.1 Chart Recorder Access

- ▶ iB, iLR, iPR models (except 111): Open door by pressing and releasing it.
- ▶ HB, iHB, HHB, HLR, HPR models (and all 111 models): Pull door open.



iB, iLR, and iPR chart recorder door.



HB, iHB, HHB, HLR, HPR, and all 111 models chart recorder door.

3.5.2 Install Chart Paper

- 1 Press and hold **C** button. When stylus begins to move left, release button. The LED flashes to indicate current temperature range.
- 2 When stylus stops moving, remove chart knob then move knob up and away.
- 3 Place chart paper on chart recorder.
- 4 Gently lift stylus and rotate paper so current time line corresponds to time line groove.



- 5 Hold chart paper and reinstall chart knob.

NOTE For accurate temperature reading, ensure that current time is aligned with time line groove when chart knob is tightened.

- 6 Confirm temperature range is set to the correct value.
- 7 Press and hold **C** button. When stylus begins to move right, release button.
- 8 Confirm stylus is marking temperature correctly.

4 Alarm Reference

If an alarm condition is met, an alarm activates. Some alarms are visual only; others are visual and audible. Some alarms are sent through the remote alarm interface.

The table indicates if an alarm is audible (A), visual (V), or sent through the remote alarm interface (R).

Alarm	Alarm Type		
	iB, iHB, iLR, iPR	HB	HHB, HLR, HPR
Door Open	A, V, R	A, V, R	A, V, R
High temperature	A, V, R	A, V, R	A, V, R
Low temperature	A, V, R	A, V, R	A, V, R
Condenser temperature	A, V, R	-	-
Low battery	V	-	-
No battery	A, V, R	-	-
AC power failure	A, V, R	A, V, R	A, V, R
Change chart paper	V	V	-

5 Compliance

5.1 Regulatory Compliance

This device complies with the requirements of directive 93/42/EEC concerning Medical Devices, as amended by 2007/47/EC.

Sound level is less than 70 dB(A).



Emergo Europe
Molenstraat 15
2513 BH
The Hague, Netherlands

5.2 WEEE Compliance

The WEEE (waste electrical and electronic equipment) symbol (right) indicates compliance with European Union Directive WEEE 2002/96/EC and applicable provisions. The directive sets requirements for labeling and disposal of certain products in affected countries.

When disposing of this product in countries affected by this directive:

- ▶ Do not dispose of this product as unsorted municipal waste.
- ▶ Collect this product separately.
- ▶ Use collection and return systems available locally.

For more information on the return, recovery, or recycling of this product, contact your local distributor.



6 Warranty

6.1 Rel.i™ Product Warranty USA and Canada

For technical service needs, please contact Helmer at 800-743-5637 or www.helmerinc.com. Have the model and serial number available when calling.

6.1.1 Rapid Resolution

When a warranty issue arises it is our desire to respond quickly and appropriately. The service department at Helmer is there for you. Helmer will oversee the handling of your warranty service from start to finish. Therefore, Helmer must give advance authorization for all service calls and/or parts needs relating to a warranty issue. Any repeat service calls must also be authorized as well. This allows for proper diagnosis and action. Helmer will not be responsible for charges incurred for service calls made by third parties prior to authorization from Helmer. Helmer retains the right to replace any product in lieu of servicing it in the field.

6.1.2 Compressor

For the warranty period listed below, Helmer will supply the refrigeration compressor, if it is determined to be defective, at no charge, including freight. Helmer will not be liable for installation, refrigerant, or miscellaneous charges required to install the compressor beyond the first year of the warranty period.

- ▶ i.Series model compressor warranty period is seven (7) years.
- ▶ Horizon Series model compressor warranty period is five (5) years.

6.1.3 Parts

For a period of two (2) years, Helmer will supply at no charge, including freight, any part that fails due to defects in material or workmanship under normal use, with the exception of expendable items. Expendable items such as glass, filters, light bulbs, and door gaskets are excluded from this warranty coverage. Inspection of defective parts by Helmer will be final in determining warranty status. Warranty procedures must be followed in all events.

6.1.4 Labor

For a period of one (1) year, Helmer will cover repair labor costs (including travel) and the cost of refrigerant and supplies necessary to perform authorized repairs. Repair service must be performed by an authorized Helmer service agency following the authorization process detailed above. Alternatively, your facility's staff may work with a Helmer technician to make repairs. Labor costs for repairs made by unauthorized service personnel, or without the assistance of a Helmer technician, will be the responsibility of the end user.

6.1.5 Additional Warranty Information

The time periods set forth above begin two (2) weeks after the original date of shipment from Helmer. Warranty procedures set forth above must be followed in all events.

THERE ARE NO WARRANTIES WHICH EXTEND BEYOND THE DESCRIPTION ON THE FACE HEREOF. THIS WARRANTY IS EXCLUSIVE AND IN LIEU OF ALL OTHER WARRANTIES, EXPRESS OR IMPLIED, INCLUDING WITHOUT LIMITATION ANY WARRANTY OF MERCHANTABILITY OR FITNESS FOR A PARTICULAR PURPOSE. NO WARRANTIES OF MERCHANTABILITY OR FITNESS FOR PARTICULAR PURPOSE SHALL APPLY.

THE LIABILITY, IF ANY, OF HELMER FOR DIRECT DAMAGES WHETHER ARISING FROM A BREACH OF ANY SALES AGREEMENT, BREACH OF WARRANTY, NEGLIGENCE, OR INDEMNITY, STRICT LIABILITY OR OTHER TORT, OR OTHERWISE WITH RESPECT TO THE GOODS OR ANY

SERVICES IS LIMITED TO AN AMOUNT NOT TO EXCEED THE PRICE OF THE PARTICULAR GOODS OR SERVICES GIVING RISE TO THE LIABILITY. IN NO EVENT SHALL HELMER BE LIABLE FOR ANY INDIRECT, INCIDENTAL, CONSEQUENTIAL, OR SPECIAL DAMAGES, INCLUDING WITHOUT LIMITATION DAMAGES RELATED TO LOST REVENUES OR PROFITS, OR LOSS OF PRODUCTS.

This warranty does not cover damages caused in transit, during installation by accident, misuse, fire, flood, or acts of God. Further, this warranty will not be valid if Helmer determines that the failure was caused by a lack of performing recommended equipment maintenance (per Helmer manual) or by using the product in a manner other than for its intended use. Installation and calibration are not covered under this warranty agreement.

6.2 Outside of USA and Canada

Consult your local distributor for warranty information.

Section II: i.Series® - All Models

NOTE This section applies to iB, iPR, iLR, and iHB models.

7 Product Configuration

7.1 Install Battery for Backup Power

The monitoring system and chart recorder each have a battery system, enabling a period of continuous operation if power is lost.

NOTE The monitoring system will not start on battery power alone. If the refrigerator was previously not connected to AC power and the batteries are installed, the monitoring system will not run on battery power.

Battery life varies by manufacturer as well as voltage level remaining. Providing full power is available and no battery-related alarms are active, backup power for the monitoring system is available for up to two hours.



NOTICE When installing replacement batteries, use only batteries which meets the specifications outlined in chapter 10.7 (Supplies).

The batteries are located on the top of the refrigerator, behind the monitoring system. For 111 models, a service cover covers the components and an access panel provides access to the monitoring system backup batteries.

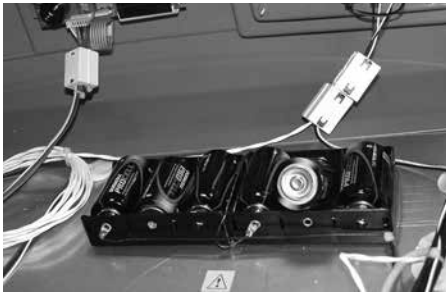

Monitoring system backup batteries.

Five batteries are installed and one battery is included in the accessory package. Install the sixth battery to provide power to the monitoring system in the event of an AC power failure.

7.2 External Monitoring Devices



- CAUTION**
- ▶ The interface on the remote alarm monitoring system is intended for connection to the end user's central alarm system(s) that uses normally-open or normally-closed dry contacts.
 - ▶ If an external power supply exceeding 30 V (RMS) or 60 V (DC) is connected to the remote alarm monitoring system's circuit, the remote alarm will not function properly; may be damaged; or may result in injury to the user.

NOTE In the event of a power failure, the power failure alarm condition is transmitted through the remote alarm contacts.

The remote alarm interface is a relay switch with three terminals:

- ▶ Common (COM)
- ▶ Normally Open (NO)
- ▶ Normally Closed (NC)

Terminals are dry contacts and do not supply voltage. Interface circuit is either normally open or normally closed, depending on terminals used. Requirements for your alarm system determine which alarm wires must connect to terminals.

- ▶ 0.5 A at 30 V (RMS): 1.0 A at 24 V (DC)

7.2.1 Connect to Remote Alarm Interface

- 1 Disconnect AC power from the refrigerator. Remove one battery from the monitoring system backup battery holder.
- 2 On back of refrigerator, locate the remote alarm terminals.
- 3 Connect remote alarm wires to appropriate terminals, according to requirements for your alarm system.
- 4 Use a cable tie to relieve strain on alarm wires (as necessary).
- 5 Reinstall the battery in the monitoring system backup battery holder. Reconnect the refrigerator to AC power.
- 6 Touch **MUTE** to disable the high temperature alarm while refrigerator reaches operating temperature.

7.3 Move Drawers, Shelves, and Baskets



Storage features.

CAUTION

- ▶ Keep hands away from pinch points when closing the door.
- ▶ Before moving drawers, ensure they are completely empty for safe lifting.
- ▶ Maximum basket, drawer, or shelf load is 100 lbs (46 kg).

NOTICE

Before moving storage components, protect stored items in refrigerator from extended exposure to adverse temperature.

Remove a drawer or basket:

- 1 Pull drawer or basket out until it stops.
- 2 On the right rail, locate the release tab and press downward.
- 3 While holding the right release tab downward, locate the release tab on the left rail and press upward.
- 4 Pull drawer or basket free of the slides.

Install a drawer or basket:

- 1 Align end guides on drawer or basket with the slides.
- 2 Gently push drawer or basket into chamber until it stops.
- 3 Pull drawer or basket out until it stops; check for smooth operation.

Remove a shelf:

- 1 With one hand, lift front edge of the shelf from the front brackets.
- 2 With the other hand, reach under the shelf and bump rear edge of the shelf upward to disengage rear brackets.

Install a shelf:

- 1 Insert shelf into chamber, placing it on brackets.
- 2 Gently bump rear edge of the shelf downward to engage brackets.
- 3 Pulling shelf forward gently; shelf should not disengage from rear brackets.

7.4 Drawer Labels

Drawer with label holder shown (labels not provided).

7.5 Move Slides and Brackets**Remove drawer slides:**

- 1 Using a screwdriver, remove front bracket retainers.
- 2 Tap front brackets upward to disengage standards.
- 3 Remove slides from standards.

Install drawer slides:

- 1 Insert slides into standard at appropriate height.
- 2 Tap front brackets downward to engage standards.
- 3 Using a screwdriver, install front bracket retainers.

Remove shelf brackets:

- 1 Using a screwdriver, remove front bracket retainers.
- 2 Tap front brackets upward to disengage standards.
- 3 Remove front brackets from standards.

Install shelf brackets:

- 1 Insert front brackets into standard at appropriate height.
- 2 Tap front brackets downward to engage standards.
- 3 Using a screwdriver, install front bracket retainers.

7.6 Optional Adapter Kits for Medication Dispensing Locks

Contact Helmer Technical Service or your distributor for service documentation pertaining to medication dispensing locks.

8 Temperature Monitor Settings

8.1 Home Screen

The HOME screen appears when:

- ▶ The **HOME** button is pressed from any other screen
- ▶ There is no interaction for two minutes on any screen other than those used to enter a password

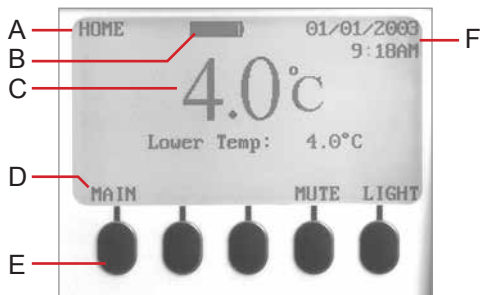

HOME screen on the monitoring system.

Label	Description
A	Screen name
B	Battery voltage level
C	Chamber temperature display
D	Button labels
E	Buttons
F	Date and time display

8.1.1 Home Screen Functions

NOTE Refer to chapter 14 (i.Center Screen Reference) for a complete list of screens in the i.Center monitoring system.

- ▶ View current temperature readings
- ▶ View the current time and date
- ▶ View detailed information about current or previous alarm events
- ▶ View the remaining backup battery charge
- ▶ View active alarms
- ▶ Mute audible alarms
- ▶ Adjust contrast
- ▶ View 24-hour chamber temperature graph
- ▶ Access Main screen to view and change settings

8.2 Main Screen

The Main screen displays functional options that allow access to all other screens in the system.



MAIN screen functional options.

Functions available from the Main screen:

Option	Function
Event Log	▶ View historical information about alarms and operational events
System Alarm Test and Status	<ul style="list-style-type: none"> ▶ Start or stop an automatic test for temperature alarms ▶ View the number of days remaining before the paper for the temperature chart recorder needs to be changed ▶ View the current status of the door (OPEN or CLOSED) ▶ View the current condenser temperature
Edit Configuration (password required)	<ul style="list-style-type: none"> ▶ Change the language used for text ▶ Change date and time information ▶ Change temperature units ▶ Change the volume and pattern for audible alarms ▶ Enable or disable the chart paper timer ▶ Enable or disable the temperature graph display ▶ Change alarm-related setpoints and timers ▶ Calibrate the temperature probe reading ▶ Change some settings to the factory default values ▶ Change the password, preventing unauthorized changes
View Configuration	<ul style="list-style-type: none"> ▶ View the date and time formats ▶ View alarm-related setpoints and timers ▶ View the volume and pattern for audible alarms ▶ View the setting for the chart paper timer ▶ View the setting for the temperature graph display ▶ View the settings for temperature and time alarms
Product/Company Information	<ul style="list-style-type: none"> ▶ View the software versions for control and display components of the monitoring system ▶ View information to contact Helmer
i.Help	▶ Access the on-board help system

8.3 Temperature Graph

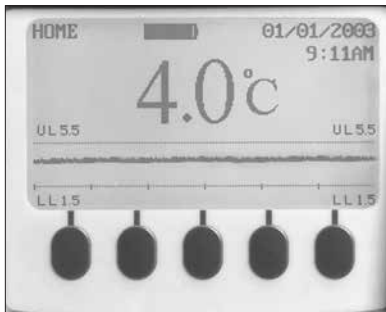

The Temperature Graph screen appears when:

- ▶ The Temperature Graph feature is enabled
- ▶ There is no interaction for one minute on any screen
- ▶ There are no active alarms

NOTE: While there is power to the monitoring system, data from the chamber temperature probe is collected real-time, and the past 24 hours of collected data is stored and displayed.

In the event of an AC power failure, the monitoring system continues to collect and display temperature data as long as battery power is available. If AC power is restored before battery power fails, there is no interruption in data collection. The temperature that is displayed on the graph for eight hours earlier was the temperature eight hours ago.

If battery power fails, the monitoring system stops displaying temperature data and stops collecting new temperature data. The past 24 hours of data temperature data is retained. When AC power is restored, the stored data is displayed, and the monitor resumes collecting and displaying real-time temperature data. In this case, there is an interruption in data collection: the temperature displayed on the graph for eight hours earlier was the temperature at eight hours before the backup power failed.

8.3.1 Enable or Disable the Temperature Graph

The i.Center has a real-time temperature graph which displays temperature probe readings for the past 24 hours of operation. This graph appears on the bottom of the HOME screen when no button has been pressed for one minute, and if no alarm is active. The graph clears if a button is pressed or an alarm activates.

NOTE: The temperature graph is enabled by default.

Enable or disable the temperature graph:

- 1 On the HOME screen, press the **MAIN** button.
- 2 Press the **DOWN** button to select Edit Configuration. Press the **SELECT** button.
- 3 Enter the password when prompted.
- 4 Press the **DOWN** button to select Alarm Setpoints. Press the **SELECT** button.
- 5 Press the **DOWN** button to select Temperature Graph.
- 6 Press the **INC** or **DEC** buttons to select enable or disable the temperature graph.
- 7 Press the **BACK** button to return to the Edit Configuration screen, or press the **HOME** button to exit.

8.4 Change Configuration Password

The default password is 1234. A new password must use four digits, ranging from 1 to 5.

Change the password:

- 1 On the HOME screen, press the **MAIN** button.
- 2 Press the **DOWN** button to select Edit Configuration. Press the **SELECT** button.
- 3 Enter the password when prompted.
- 4 Press the **DOWN** button to select Change Password. Press the **SELECT** button.
- 5 Enter the new password, then re-enter the new password when prompted.
 - ▶ If password entries match, the “update” message is displayed.
 - ▶ If password entries do not match, the “incorrect match” message is displayed. Repeat the procedure to change the password.

8.5 Calibrate Chamber Temperature Probe

Verify the temperature probe is reading chamber temperature correctly by comparing the chamber probe reading to temperature read by an independent thermometer. If the chamber temperature probe is not reading correctly, change the value displayed on the temperature monitoring system.

NOTE If the variance is within acceptable limits for your organization, changing probe settings is optional.

- ▶ Default setting for chamber temperature is 4.0 °C
- ▶ Value is factory-preset

Obtain:

- ▶ Independent thermometer, calibrated and traceable per national standards

Measure the chamber temperature:

- 1 Remove the probe from the probe bottle.
- 2 Unscrew the cap from the bottle.
- 3 Insert the thermometer and temperature probe in the bottle. The probe and thermometer should be immersed at least 2” (50 mm).
- 4 Close the door and allow the chamber temperature to stabilize for 10 minutes.
- 5 Observe and note the thermometer temperature.

EXAMPLE

- ▶ Measured temperature (at the probe bottle) is 4.0 °C
- ▶ Displayed temperature is 4.5 °C
- ▶ Change displayed temperature to 4.0 °C

Enter the new calibration value:

- 1 On the HOME screen, press the **MAIN** button.
- 2 Press the **DOWN** button to highlight Edit Configuration. Press the **SELECT** button.
- 3 Enter the password when prompted.
- 4 Press the **DOWN** button to highlight Temperature Calibration. Press the **SELECT** button.
 - a The Select Temp Probe: (Upper or Lower) option is highlighted.
 - b Press the **INC** or **DEC** buttons to select the Upper or Lower probe option.
 - c Press the **DOWN** button to highlight Temperature.
 - d Press the **INC** or **DEC** buttons to change the temperature calibration value.

- 5 Press the **DOWN** button to highlight Store Calibration.
 - a To save the new value, press the **ENTER** button. The “Calibration Memorized” message appears. New settings are saved.
 - b To discard the new value, press the **BACK** button or **HOME** button to exit. New settings are not saved.
- 6 Remove thermometer and probe from bottle.
- 7 Replace the probe in probe bottle.
- 8 Replace bottle cap, ensuring a tight fit.
- 9 Place the probe in bottle, immersing at least 2” (50 mm).

NOTE

- ▶ The current temperature displayed by the monitoring system may change so that it no longer matches the new probe calibration value. This is normal.
- ▶ If a new probe value is entered but not saved, the new value will appear when the calibration setting for the probe is viewed. This is normal.

8.6

Factory Default Settings

Settings listed below may be simultaneously returned to factory default values.

NOTE The factory default settings may not be the same as the settings that were factory-calibrated before the refrigerator was shipped.

Setting	Restored Value
High Alarm Setpoint	5.5 °C
Low Alarm Setpoint ⁽¹⁾	1.5 °C
Condenser Alarm Setpoint	50.0 °C
Door Ajar Timeout	3 minutes
Power Failure Timeout	3 minutes
Chart Paper Timer	6.5 days

(1) This includes laboratory (iLR) and pharmacy (iPR) models that were originally set at 2.0 °C.

NOTE Unless your organization requires the Low Alarm Setpoint to be at the factory default level of 1.5 °C, it will be necessary to increase the setpoint to 2.0 °C after restoring factory defaults.

8.7

Restore Factory Default Settings

Restore settings:

- 1 Press the **MAIN** button.
- 2 Press the **DOWN** button to highlight Edit Configuration. Press the **SELECT** button.
- 3 Enter the password when prompted.
- 4 Press the **DOWN** button to highlight Factory Default Settings. Press the **SELECT** button.
- 5 Do one of the following:
 - ▶ Press the **ENTER** button. Factory default settings are restored.
 - ▶ Press the **BACK** button. Factory default settings are not restored.

8.8 Alarm Settings

The following alarm settings may be changed by the operator. The setpoint for temperature alarms may be changed (where applicable), as well as the time delay between when the alarm condition commences and when the visual and audible alarms are initiated.

8.8.1 Alarm Volume

The alarm volume can be changed. The Alarm Volume controls volume for all audible alarms.

- ▶ Default setting is 10
- ▶ Setting can be changed from 1 to 10
- ▶ 1 is the quietest setting; 10 is the loudest setting

Change the alarm volume:

- 1 Press the **MAIN** button.
- 2 Press the **DOWN** button to highlight Edit Configuration. Press the **SELECT** button.
- 3 Enter the password when prompted.
- 4 Press the **DOWN** button to highlight System Options. Press the **SELECT** button.
- 5 Press the **DOWN** button to highlight Alarm Volume.
- 6 Press the **INC** or **DEC** buttons to change the setting.
- 7 Press the **BACK** button to return to the Edit Configuration screen, or press the **HOME** button to exit.
The new settings are saved.

8.8.2 Alarm Pulse

The alarm pattern can be changed. This is useful if several refrigerators with alarms are collocated, and distinguishing the source of the alarm quickly is desirable.

- ▶ Default setting is Single.
- ▶ Setting can be changed between Single, Double, Triple, and Constant.

Change the alarm pulse:

- 1 Press the **MAIN** button.
- 2 Press the **DOWN** button to highlight Edit Configuration. Press the **SELECT** button.
- 3 Enter the password when prompted.
- 4 Press the **DOWN** button to highlight System Options. Press the **SELECT** button.
- 5 Press the **DOWN** button to highlight Alarm Pulse.
- 6 Press the **INC** or **DEC** buttons to change the setting.
- 7 Press the **BACK** button to return to the Edit Configuration screen, or press the **HOME** button to exit.
The new settings are saved.

8.8.3 High Chamber Temperature Alarm

The High Alarm setpoint specifies the temperature at which the High Temperature Alarm activates. If the temperature detected by the chamber probe is greater than or equal to this value, the alarm activates.

- ▶ Default setpoint is 5.5 °C
- ▶ Setpoint can be changed from -40 °C to +40 °C

Change the setpoint:

- 1 Press the **MAIN** button.
- 2 Press the **DOWN** button to highlight Edit Configuration. Press the **SELECT** button.
- 3 Enter the password when prompted.
- 4 Press the **DOWN** button to highlight Alarm Setpoints. Press the **SELECT** button.
- 5 Press the **DOWN** button to highlight High Alarm Setpoint.
- 6 Press the **INC** or **DEC** buttons to change the setting.

- 7 Press the **BACK** button to return to the Edit Configuration screen, or press the **HOME** button to exit. The new settings are saved.

8.8.4 Low Chamber Temperature Alarm

The Low Alarm setpoint specifies the temperature at which the Low Temperature Alarm activates. If the temperature detected by the chamber probe is less than or equal to this value, the alarm activates.

- ▶ Default setpoint is 1.5 °C (iB models)
- ▶ Default setpoint is 2.0 °C (iLR models)
- ▶ Setpoint can be changed from -40 °C to +40 °C

Change the setpoint:

- 1 Press the **MAIN** button.
- 2 Press the **DOWN** button to highlight Edit Configuration. Press the **SELECT** button.
- 3 Enter the password when prompted.
- 4 Press the **DOWN** button to highlight Alarm Setpoints. Press the **SELECT** button.
- 5 Press the **DOWN** button to highlight Low Alarm Setpoint.
- 6 Press the **INC** or **DEC** buttons to change the setting.
- 7 Press the **BACK** button to return to the Edit Configuration screen, or press the **HOME** button to exit. The new settings are saved.

8.8.5 Condenser Temperature Alarm

The Condenser Alarm setpoint specifies the temperature at which the Condenser Temperature Alarm activates. If the temperature of the condenser discharge line is greater than or equal to this value, the alarm activates.

- ▶ Default setpoint is 50 °C
- ▶ Setpoint can be changed from -40 °C to +80 °C



NOTICE Condenser Temperature Alarm should not be changed unless directed by Helmer Technical Service.

Change the setpoint:

- 1 Press the **MAIN** button.
- 2 Press the **DOWN** button to highlight Edit Configuration. Press the **SELECT** button.
- 3 Enter the password when prompted.
- 4 Press the **DOWN** button to highlight Alarm Setpoints. Press the **SELECT** button.
- 5 Press the **DOWN** button to highlight Cond. Alarm Setpoint.
- 6 Press the **INC** or **DEC** buttons to change the setting.
- 7 Press the **BACK** button to return to the Edit Configuration screen, or press the **HOME** button to exit. The new settings are saved.

8.8.6 Door Ajar Alarm

The Door Ajar Timeout specifies longest time the refrigerator door can be open before the alarm activates. If the time elapsed since the last door opening is greater than or equal to this value, the alarm activates.

- ▶ Default delay setting is three minutes
- ▶ Setting can be changed from 0 minutes to 60 minutes

Change the alarm delay:

- 1 Press the **MAIN** button.
- 2 Press the **DOWN** button to highlight Edit Configuration. Press the **SELECT** button.

- 3 Enter the password when prompted.
- 4 Press the **DOWN** button to highlight Alarm Setpoints. Press the **SELECT** button.
- 5 Press the **DOWN** button to highlight Door Ajar Timeout.
- 6 Press the **INC** or **DEC** buttons to change the setting.
- 7 Press the **BACK** button to return to the Edit Configuration screen, or press the **HOME** button to exit. The new settings are saved.

8.8.7 Power Failure Alarm

The Power Failure Timeout specifies longest time the refrigerator can be without AC power before the alarm activates. If the time elapsed since the last power failure is greater than or equal to this value, the alarm activates.

- ▶ Default delay setting is three minutes
- ▶ Setting can be changed from 0 minutes to 60 minutes

Change the alarm delay:

- 1 Press the **MAIN** button.
- 2 Press the **DOWN** button to highlight Edit Configuration. Press the **SELECT** button.
- 3 Enter the password when prompted.
- 4 Press the **DOWN** button to highlight Alarm Setpoints. Press the **SELECT** button.
- 5 Press the **DOWN** button to highlight Power Failure Timeout.
- 6 Press the **INC** or **DEC** buttons to change the setting.
- 7 Press the **BACK** button to return to the Edit Configuration screen, or press the **HOME** button to exit. The new settings are saved.

8.8.8 Chart Paper Alarm

The default setting for the chart paper timer is Enabled. One sheet of chart paper records temperatures continuously for seven days. The timer activates an alarm 6.5 days from when the timer is reset. The timer period cannot be changed.

-
- NOTE**
- ▶ Available options are Enabled, Disabled, and Reset.
 - ▶ Enabling the timer also resets the timer.
-

Change the setting:

- 1 Press the **MAIN** button.
- 2 Press the **DOWN** button to highlight Edit Configuration. Press the **SELECT** button.
- 3 Enter the password when prompted.
- 4 Press the **DOWN** button to highlight System Options. Press the **SELECT** button.
- 5 Press the **DOWN** button to highlight Chart Paper Timer.
- 6 Press the **INC** or **DEC** buttons to select Enabled, Disabled, or Reset.
- 7 Do one of the following:
 - ▶ If Enabled or Disabled is selected, press the **BACK** button to return to the System Options screen, or press the **HOME** button to exit. The new setting is saved.
 - ▶ If Reset is selected:
 - a Press the **DOWN** button.
 - b Press the **PAPER-CHANGED** button. The System Options screen appears with the Chart Paper Timer set to Enabled.
- 8 Press the **BACK** button to return to the System Options screen, or press the **HOME** button to exit. The new setting is saved.

8.9 Test Alarms

Test alarms to ensure they are working correctly. The refrigerator has alarms for chamber temperature, compressor temperature, door open (time), no battery, and power failure.



NOTICE Before testing alarms, protect items in the refrigerator from extended exposure to adverse temperature.

8.9.1 Automatic Chamber Temperature Alarm Test

NOTE

- ▶ Calibrate the chamber temperature probe prior to performing the Automatic Chamber alarm test.
- ▶ The test can be aborted by selecting the Cancel High or Low Test option.
- ▶ The test takes less than five minutes.

When performing an automatic temperature alarm test, the Peltier device heats or cools the temperature probe until the high or low alarm setpoint is reached. An event is added to the Event Log to indicate a temperature alarm was activated.

Test the low alarm:

- 1 Identify the current setting for the low alarm setpoint.
- 2 Press the **MAIN** button.
- 3 Press the **DOWN** button to select System Alarm Test & Status. Press the **SELECT** button.
 - ▶ The System Alarm Test & Status screen appears.
- 4 Press the **DOWN** button to select Start Low Alarm Auto Test. Press the **SELECT** button.
 - ▶ The “Low Alarm Test in Progress” message appears.
 - ▶ The alarm will activate when the alarm setpoint is reached.
 - ▶ When the test is complete, the message clears.
- 5 View the Event Log. Note the temperature at which the low alarm occurred. Compare the temperature to the low alarm setpoint. If the values do not match, refer to chapter 11 (Troubleshooting).

Test the high alarm:

- 1 Identify the current setting for the high alarm setpoint.
- 2 Press the **MAIN** button.
- 3 Press the **DOWN** button to select System Alarm Test & Status. Press the **SELECT** button.
 - ▶ The System Alarm Test & Status screen appears.
- 4 Press the **DOWN** button to select Start High Alarm Auto Test. Press the **SELECT** button.
 - ▶ The “High Alarm Test in Progress” message appears.
 - ▶ The alarm will activate when the alarm setpoint is reached.
 - ▶ When the test is complete, the message clears.
- 5 View the Event Log. Note the temperature at which the high alarm occurred. Compare the temperature to the high alarm setpoint. If the values do not match, refer to chapter 11 (Troubleshooting).

Cancel the test:

- 1 Press the **MAIN** button.
- 2 Press the **DOWN** button to select System Alarm Test & Status. Press the **SELECT** button.
 - ▶ The System Alarm Test & Status screen appears.
- 3 Press the **DOWN** button to select Cancel High or Low Test. Press the **ENTER** button.
 - ▶ The test is cancelled.

NOTE When cancelling an automatic test, the message indicating the test is in progress clears immediately. If a setpoint was reached before the test was cancelled, the alarm activates and clears, as described earlier.

8.9.2

Manual Chamber Alarm Test

NOTICE Before testing alarms, protect items in refrigerator from extended exposure to adverse temperature.

IMPORTANT Perform the low alarm test before the high alarm test to control the temperature more closely and complete the testing more quickly.

Obtain:

- ▶ (2) 8 oz. (250 mL) glass half-full of chilled water
 - ▶ (1) glass filled with crushed ice
 - ▶ (1) 8 oz. (250 mL) glass half-full of warm water
-



NOTICE Temperature probes are fragile; handle with care.

Test the low alarm:

- 1 Identify setting for low alarm setpoint.
- 2 Remove chamber temperature probe from bottle.
- 3 Immerse probe in chilled water.
- 4 While stirring probe in chilled water, add approximately one teaspoon (5 mL) of ice every 20 seconds. Ensure probe is at the bottom of the glass.
- 5 When low temperature alarm activates, note the temperature on the i.Center display.
- 6 Compare the temperature at which the alarm activates to the low alarm setpoint. If values do not match, calibrate the temperature probe.

Test the high alarm:

- 1 Identify setting for high alarm setpoint.
- 2 While stirring probe in chilled water, add warm water so temperature increases 0.5 °C per minute.
- 3 When high temperature alarm activates, note the temperature on the i.Center display.
- 4 Compare the temperature at which the alarm activates to the high alarm setpoint. If values do not match, calibrate the temperature probe.
- 5 Remove probe from warm water.
- 6 Place temperature probe in probe bottle, immersing it at least 2" (50 mm).

8.9.3 Power Failure Alarm Test

- NOTE**
- ▶ During a power failure, the power failure alarm activates and the batteries provide power to the monitoring system.
 - ▶ If AC power fails, the backup batteries will allow for continued data collection and temperature display.
 - ▶ If the backup batteries fail, data is not collected and the temperature is not displayed.
 - ▶ When power is restored, the 24 hours of data prior to the power loss are retained in the system memory. Stored temperature data is displayed on the graph and the monitoring system resumes data collection and display.

- 1 Confirm the refrigerator is connected to AC power.
- 2 Ensure the monitoring system backup batteries are installed.
- 3 Change Power Failure Timeout setting to 0 minutes.
 - a Press the **MAIN** button.
 - b Press the **DOWN** button to highlight Edit Configuration. Press the **SELECT** button.
 - c Enter the password when prompted.
 - d Press the **DOWN** button to highlight Alarm Setpoints. Press the **SELECT** button.
 - e Press the **DOWN** button to highlight Power Failure Timeout.
 - f Press the **DEC** button to change the setting to 0.
- 4 Disconnect the refrigerator from AC power. Power failure alarm will activate immediately.
- 5 Reconnect the refrigerator to AC power. Power failure alarm will clear and audible alarm will cease.
- 6 Change the Power Failure Timeout setting to the original setting.

8.9.4 Door Ajar Alarm Test

- 1 Change Door Ajar Timeout setting to 0 minutes:
 - a Press the **MAIN** button.
 - b Press the **DOWN** button to highlight Edit Configuration. Press the **SELECT** button.
 - c Enter the password when prompted.
 - d Press the **DOWN** button to highlight Alarm Setpoints. Press the **SELECT** button.
 - e Press the **DOWN** button to highlight Door Ajar Timeout.
 - f Press the **DEC** button to change the setting to 0.
 - g Press the **BACK** button to return to the Edit Configuration screen, or press the **HOME** button to exit. New settings are saved.
- 2 Open the door. Door ajar alarm will activate immediately.
- 3 Close the door. Door ajar alarm will clear and audible alarm will cease.
- 4 Change the Door Ajar Timeout setting to the original setting.

8.9.5 No Battery Alarm Test

Test the no battery alarm to ensure the alarm provides warning of a low- or no-battery charge.

- NOTE**
- ▶ During an AC power failure, the power failure alarm activates and the batteries provide power to the monitoring system.
 - ▶ If AC power fails, the backup batteries will allow for continued data collection and temperature display.
 - ▶ If the backup batteries fail, data is not collected and the temperature is not displayed.

Test the alarm:

- 1 Ensure the monitoring system backup batteries are installed.
- 2 Remove one battery from the monitoring system backup battery holder.
 - a If the no battery alarm activates, no further action is needed. Reinstall the battery.
 - b If the no battery alarm does not activate, contact Helmer Technical Service.



NOTICE When installing replacement batteries, use only batteries which meet the specifications outlined in chapter **10.7** (Supplies).

8.10 Additional System Settings

8.10.1 Screen Contrast

The screen contrast can be changed for easier viewing.

- NOTE**
- ▶ During an AC power failure, the screen backlight is not illuminated to conserve backup battery power.
 - ▶ During an AC power failure, the screen contrast cannot be changed.

Change screen contrast:

- 1 On the HOME screen, press the third button from the left to make the text appear lighter.
- 2 On the HOME screen, press the second button from the left to make the text appear darker.

8.10.2 Date and Time

The Date Format setting controls the order in which the month (mm) and day (dd) are displayed.

- ▶ Month is a 2-digit number (01-12)
- ▶ Day is a 2-digit number (01-31)
- ▶ Default date format is mm/dd/yyyy

The Clock Mode setting controls whether the time is displayed in a 12-hour or 24-hour format.

- ▶ When using the 12-hour format, AM or PM must be specified
- ▶ Default setting is 12-hour

Change date and time settings:

- 1 Press the **MAIN** button.
- 2 Press the **DOWN** button to highlight Edit Configuration. Press the **SELECT** button.
- 3 Enter the password when prompted.
- 4 Press the **DOWN** button to highlight Set Date & Time. Press the **SELECT** button.
- 5 Press the **UP** or **DOWN** buttons to select the date and time settings to change.
- 6 Press the **INC** or **DEC** buttons to change the setting.
- 7 Press the **BACK** button to return to the Edit Configuration screen, or press the **HOME** button to exit. The new settings are saved.

8.10.3 Display Language

The i.Center monitoring system stores two languages. English is the default language. If a different language is desired, it must be loaded from the flash memory card. If a flash memory card is not included with the refrigerator, the languages may have been loaded to the i.Center prior to shipment.

To obtain a flash memory card to load an alternate language, contact Helmer Technical Service.

NOTE Each time the refrigerator is powered on, the i.Center display language must be selected.

Set the display language on power-on:

- 1 Connect the refrigerator to AC power.
- 2 Install the monitoring system battery that is included in the accessory package.
 - ▶ The refrigerator powers on and the i.Center will display the System Options screen.
- 3 Press the **INC** or **DEC** buttons to select the desired language. Press the **SELECT** button.
- 4 Press the **HOME** button to return to the HOME screen.
- 5 If a temperature alarm sounds, press the **MUTE** button.

Change the display language:

- 1 Press the **MAIN** button.
- 2 Press the **DOWN** button to highlight Edit Configuration. Press the **SELECT** button.
- 3 Enter the password when prompted.
- 4 Press the **DOWN** button to highlight System Options. Press the **SELECT** button.
- 5 Press the **UP** or **DOWN** buttons to select Language. Press the **SELECT** button.
- 6 Press the **INC** or **DEC** buttons to select the desired language.
- 7 Press the **BACK** button to return to the System Options screen, or press the **HOME** button to exit.
The new settings are saved.

8.10.4 Temperature Units

Available options are Celsius (°C) or Fahrenheit (°F). The default temperature unit is Celsius.

Change temperature units:

- 1 Press the **MAIN** button.
- 2 Press the **DOWN** button to highlight Edit Configuration. Press the **SELECT** button.
- 3 Enter the password when prompted.
- 4 Press the **DOWN** button to highlight System Options. Press the **SELECT** button.
- 5 Press the **DOWN** button to highlight Temperature Units.
- 6 Press the **INC** or **DEC** buttons to select the desired temperature units.
- 7 Press the **BACK** button to return to the Edit Configuration screen, or press the **HOME** button to exit.
The new setting is saved.

8.11 Event Log

The Event Log shows information from alarm events.

- ▶ 50 (most recent) events can be viewed on the Event Log screen.
- ▶ Number of door openings for the current and previous day can be viewed.

View the event log:

- 1 Press the **MAIN** button.
- 2 Press the **DOWN** button to highlight Event Log. Press the **SELECT** button.
 - ▶ The Event Log screen is displayed.

Event log format:

```
EVENT LOG Door  AA/AA BB/BB
                Openings:  C    D
EE F GG HH/HH/HH II:IJ KK.KK°L
```

Item	Description
AA/AA	Current date (month and day)
BB/BB	Previous date (month and day)
C	Number of door openings on current date
D	Number of door openings on previous date
EE	Event number. The most recent event is numbered as 1. Values can be 1-50.
F	Event. "S" indicates the start of an alarm condition. "R" indicates the alarm was reset and the system returned to normal.
GG	Alarm Type: DR Door Open HI High temperature LO Low temperature CO Condenser temperature NB No Battery AC Power failure
HH/HH/HH	Date of event (month and day, and the last two digits of the year)
II:II	Time (hours and minutes) of event
J	Time (appears for 12-hour format). "A" indicates AM. "P" indicates PM.
KK.KK	Chamber temperature at time of event
L	Temperature units. C = Celsius. F = Fahrenheit.

8.11.1 Event Details

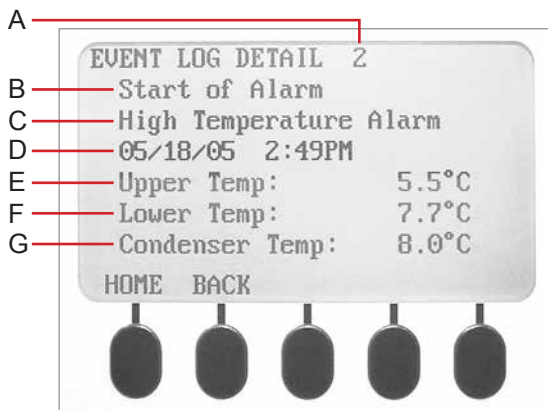

Event Log Detail screen.

Label	Description
A	Event number
B	Event
C	Alarm Type
D	Date and time of event
E	Upper chamber probe temperature at time of event
F	Lower chamber probe temperature at time of event
G	Condenser temperature at time of event

View an event:

- 1 Press the **MAIN** button.
- 2 Press the **DOWN** button to highlight Event Log. Press the **SELECT** button.
- 3 From the Event Log screen, press the **UP** or **DOWN** buttons to highlight the desired event number. Press the **SELECT** button.
 - ▶ The Event Log Detail screen for the selected event is displayed.
- 4 Press the **BACK** button to return to the Event Log screen, or press the **HOME** button to exit.

NOTE If the event is highlighted the alarm for that event was caused by a system self-test, initiated by an operator.

8.12 Upgrade System Firmware

Helmer may occasionally issue updates for the i.Center firmware. Follow upgrade instructions included with the firmware update.

8.13 Reset the i.Center Monitoring System

- 1 Remove 1 battery from the monitoring system backup battery holder.
- 2 Disconnect the refrigerator from AC power.
- 3 Reconnect the refrigerator to AC power.
- 4 Reinstall the battery in the monitoring system backup battery holder.

8.14 View Manufacturer and Product Information

- 1 Press the **MAIN** button.
- 2 Press the **INC** or **DEC** buttons to select the Product/Company Information option. Press the **SELECT** button.
 - ▶ Manufacturer contact information appears.
 - ▶ Software version appears.

9 Temperature Controller Setpoints

Temperature controller display and buttons.

The temperature controller is located in the electrical box on the rear of the refrigerator. Temperature controller setpoints are programmed at the factory. Setpoints can be viewed and changed through the temperature controller. Parameter values reside in four program levels.

View or change parameter values:

NOTICE Changing parameter values affects refrigerator operation. Do not change parameter values unless instructed by Helmer Technical Service.

NOTE

- ▶ To change the value for a parameter, first enter the program mode for that level.
- ▶ When there is no interaction for 60 seconds, the temperature controller exits program mode.

- 1 Enter Level 1 program mode:
 - a Press and hold the **UP** and **DOWN** buttons simultaneously for approximately three seconds.
 - b “tunE” and “oFF” flash on the display.
 - c The temperature controller is now in Level 1 program mode.
- 2 Select the parameter to be changed:
 - a Press and release the **UP** or **DOWN** buttons until the desired parameter flashes on the display.
 - b To access Level 2 or Level 3 parameters, select the “LEVL” parameter.
- 3 Change a parameter value:
 - a Press and hold the * button.
 - b Press the **UP** or **DOWN** buttons to change the parameter value.
 - c To access Level 2 parameters, change the value for the “LEVL” parameter to 2.
 - d To access Level 3 parameters, change the value for the “LEVL” parameter to 3.
- 4 Release all buttons to exit the parameter. New settings are saved.
 - ▶ If the “LEVL” parameter value is changed, the temperature controller returns to the selected program level.
- 5 Repeat steps 2 through 4 to access another program level, or to view or change parameter values in the selected level.

- 6 Access Level 4 parameters:
 - a Navigate to Level 3 program mode.
 - b Select the “UEr” parameter.
 - c Press and hold the **UP** and **DOWN** buttons simultaneously for approximately 10 seconds.
 - d The “LOCK” parameter flashes on the display.
- 7 Exit program mode:
 - a Press and hold the **UP** and **DOWN** arrow buttons simultaneously for approximately three seconds, or
 - b the current chamber temperature is displayed.

9.1

Level 1 Parameters and Values

- NOTE**
- ▶ Parameters are listed in order of appearance.
 - ▶ The temperature controller is programmed at the factory with a refrigerator setpoint of 4.0 °C.

Parameter	Description	Default Value
<i>tunE</i>	Autotune selection	oFF
<i>bAnd</i>	SP1 proportional band (gain) or hysteresis (in °C)	iLR111 / iPR111 models: 1.5 All other models: 4.0
<i>int.t</i>	SP1 integral time/reset (in minutes)	oFF
<i>dEr.t</i>	SP1 derivative time/rate	oFF
<i>dAC</i>	SP1 derivative approach control	0.5
<i>CYC.t</i>	SP1 mode selection (ON/OFF or proportional cycle-time)	on.oF
<i>oFS.t</i>	SP1 offset (manual reset)	0.0
<i>SPL.t</i>	Lock main setpoint	oFF
<i>SP.r.r</i>	Ramp rate (if ramp is on)	0
<i>SP.r.n</i>	Ramp selection	oFF
<i>SoAK.t</i>	Soak time selection	--
<i>ALLo</i>	SP2 low alarm setpoint (in °C)	0.0
<i>ALHi</i>	SP2 high alarm setpoint (in °C)	0.0
<i>bnd.2</i>	SP2 hysteresis or proportional band (in °C)	0.1
<i>CYC.2</i>	SP2 mode selection (ON/OFF or proportional cycle-time)	on.oF
<i>LEUL</i>	Parameter level currently selected	1

9.2 Level 2 Parameters and Values

Parameter	Description	Default Value
<i>SP IP</i>	Display of SP1 output power percentage (read-only)	(read only)
<i>hAnd</i>	Selection for manual control of power for SP1	oFF
<i>PL.1</i>	SP1 power limit percentage	100
<i>PL.2</i>	SP2 power limit percentage (cooling)	0
<i>SP2.A</i>	Main SP2 operating mode (alarm strategy)	nonE
<i>SP2.b</i>	Subsidiary SP2 mode	nonE
<i>d, SP</i>	Display resolution	0.1°
<i>hi.SC</i>	Full scale	20.0
<i>LoSC</i>	Minimum scale	0.0
<i>, nPt</i>	Input sensor type	rtd
<i>uni t</i>	Units (°C/ °F)	°C
<i>LEUL</i>	Parameter level currently selected	2

9.3 Level 3 Parameters and Values

Parameter	Description	Default Value
<i>SP Id</i>	SP1 output device type	SSd1
<i>SP2.d</i>	SP2 output device type (read only)	SSd2
<i>burn</i>	Sensor burn-out protection type (upscale or downscale)	uP.SC
<i>rEUD</i>	Output mode (reverse or direct)	1d.2d
<i>rEUL</i>	LED indicator modes for SP1 and SP2 (normal or inverted)	1i.2n
<i>SPAN</i>	Sensor span adjust	0.0
<i>ZEro</i>	Zero sensor error (calibration across full scale)	0.0
<i>ChEE</i>	Selection for the control accuracy monitor	oFF
<i>rEAd</i>	Read control accuracy monitor results (variance)	UAr°
<i>tECh</i>	Read autotune tuning cycle data	Ct A
<i>UEr</i>	Software version (Select this parameter to access Level 4 parameters)	392b
<i>rSEt</i>	Functions reset	nonE
<i>LEUL</i>	Parameter level currently selected	3

9.4 Level 4 Parameters and Values

Parameter	Description	Default Value
LoCK	Program security lock	nonE
dEr.S	Derivative sensitivity	0.5
di.S.S	Display sensitivity (or direct display of input)	dir
noAL	Disable SP2 alarm annunciator	oFF
ProG	Program mode auto-exit switch (returns display to normal mode if no activity for one minute)	Auto

9.5 Change the Refrigerator Setpoint



Independent temperature controller.



NOTICE

- ▶ Do not change the setpoint to a value outside the temperature control range.
- ▶ Parameter values are factory-preset and should not be changed unless directed by Helmer Technical Service.

NOTE

- ▶ Default setpoint varies for each refrigerator.
- ▶ Setpoint is adjusted to achieve an average chamber temperature of 4.0 °C.
- ▶ The reference temperature displayed on the temperature controller may not be the same as the temperature displayed on the i.Center monitor.
- ▶ Allow the temperature to stabilize for 10 minutes prior to changing the setpoint again.

- 1 Observe the average chamber temperature displayed on the i.Center monitoring system, after the monitoring system probe has been calibrated.
- 2 Determine how much the refrigerator setpoint will be changed.

EXAMPLE

- ▶ Average observed temperature is 3.5 °C
- ▶ Desired average temperature is 4.0 °C
- ▶ Current setpoint is 6.0 °C
- ▶ Adjust setpoint to 6.3 °C

- 3 Access the setpoint adjustment function:
 - a Press and hold the * button.
 - ▶ The controller displays current setpoint value.
- 4 Change the setpoint by the setpoint adjustment value:
 - a Press and hold the * button.
 - b Press the **UP** or **DOWN** buttons to increase or decrease setpoint in increments of 0.1 °C.
- 5 Release all buttons to exit the setpoint parameter. New settings are saved.

9.6 Change the Hysteresis Value

- ▶ Default setpoint for iB and iHB models is 4.0 °C
- ▶ Default setpoint for iLR111 and iPR111 models is 1.5 °C
- ▶ Allowable temperature variance on each side of the refrigerator setpoint



NOTICE Hysteresis is factory-preset and should not be changed unless directed by Helmer Technical Service.

10 Maintenance



- NOTICE**
- ▶ Before performing maintenance, protect items in refrigerator from extended exposure to adverse temperature.
 - ▶ Allow refrigerator temperature to stabilize at setpoint after performing service or after extended door opening.

NOTE Refer to the operation manual for the preventive maintenance schedule.

10.1 Recharge Refrigerant



- CAUTION**
- ▶ Review all safety instructions prior to recharging refrigerant. Refer to chapter 2 (Safety).
 - ▶ Maintenance should only be performed by trained refrigeration technicians.



NOTICE Use only non-CFC R-134A refrigerant.

Full initial refrigerant charge varies by model and power requirements, which can be found on the product specification label.

Model	Voltage	Initial Charge
111	Any	7.5 oz. (213 g)
120/125	Any	10.0 oz. (283 g)
245/256	115 V, 60 Hz	Contact Helmer Technical Service
	230 V, 50/60 Hz	20.0 oz. (567 g)

Obtain:

- ▶ Refrigerant
- ▶ Calibrated pressure gauge (0 psi to 25 psi (0 kPa to 175 kPa))

Add refrigerant:

- 1 Attach pressure gauge to the fittings on the refrigeration lines.
- 2 Monitor the low side (suction) pressure through a full compressor cycle.
- 3 Measure the pressure at the end of the next cycle, immediately before the compressor stops.

NOTE Pressure varies depending on ambient air temperature.

- 4 Add refrigerant. Check the pressure on the low side.
 - ▶ Low side = 16 psi to 18 psi (110 kPa to 125 kPa)
- 5 Remove pressure gauge.

10.2 Test Monitoring System Backup Batteries

The i.Center monitoring system has visual indicators for battery charge level. If the batteries deplete to a particular voltage output, a flashing Low Battery alarm is initiated. If the batteries are missing or nearly depleted, the flashing No Battery alarm initiates.

Test backup batteries:

- 1 Disconnect the refrigerator from AC power.
 - ▶ Screen should continue to display information without backlight.
 - ▶ If the display is blank, replace batteries.
- 2 Reconnect the refrigerator to AC power.

10.3 Replace Monitoring System Backup Batteries

- 1 Remove the access panel on the top of the refrigerator (111 models only).
- 2 On the top of the refrigerator, remove six batteries and replace with six new batteries.



NOTICE When installing replacement batteries, use only batteries which meets the specifications outlined in chapter **10.7** (Supplies).

- 3 Close the access panel (111 models only).

10.4 Replace the Fluorescent Lamps

- 1 Disconnect the refrigerator from AC power. Remove one battery from the monitoring system backup battery holder.
- 2 Single-door refrigerators: Remove drawers, shelves, baskets, and slides on the right side of the chamber.
- 3 Press short side of diffuser and unsnap it to remove from the light base.
- 4 Rotate defective light bulb and remove from the sockets.
- 5 Insert new light bulb into the sockets and rotate to lock into place.
- 6 Snap diffuser into the light base.
- 7 Reinstall the battery in the monitoring system backup battery holder. Reconnect the refrigerator to AC power.
- 8 Single-door refrigerators: Replace drawers, shelves, baskets, and slides.
- 9 Press the **MUTE** button to disable the high temperature alarm while refrigerator reaches operating temperature.

10.5 Clean the Refrigerator

10.5.1 Condenser Grill

In environments where refrigerator is exposed to excessive lint or dust, condenser grill may require cleaning more frequently than stated in preventive maintenance schedule.

Clean the condenser grill using a soft brush and a vacuum cleaner.

10.5.2 Exterior

Clean exterior surfaces with soft cotton cloth and non-abrasive liquid cleaner.

10.5.3 Interior

Clean painted surfaces with mild detergent. Clean stainless steel surfaces with a general-purpose laboratory cleaner suitable for stainless steel.

10.5.4 Door Gaskets

Clean with soft cloth and mild soap and water solution.

10.5.5 Clean and Refill Probe Bottle

NOTE A kit that includes a probe bottle and glycerin is available from Helmer.

Obtain:

- ▶ Fresh water-bleach solution (not provided)
 - ▶ 1:9 ratio of bleach to water
 - ▶ Bleach is 5% solution of commercial sodium hypochlorite (NaOCl)
 - ▶ Equivalent oxidizing cleaner/disinfectant approved by your organization may be substituted
- ▶ 4 oz. (120 mL) of product simulation solution per bottle
 - ▶ 10:1 ratio of water to glycerin

Clean and refill bottle:

- 1 Remove probe from bottle.
- 2 Remove bottle from bracket.
- 3 Clean bottle with water-bleach solution.
- 4 Fill bottle with 4 oz. (120 mL) of product simulation solution.
- 5 Cap bottle tightly to minimize evaporation.
- 6 Place bottle in bracket.
- 7 Replace probe, immersing at least 2" (50 mm).

10.6 Unit Cooler Cover Removal and Installation

If unit cooler cover is not removed as detailed in this procedure the drain port may be damaged. Improper drainage may result in excessive icing and refrigerator's inability to maintain temperature.

Required tools:

- ▶ 5/16" socket wrench
- ▶ Tool to push putty away from the drain hose

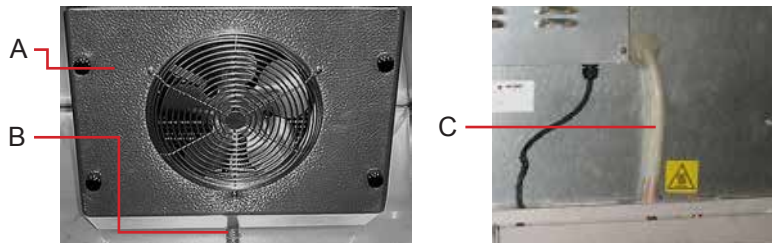

Drain line and hose.

Label	Description
A	Unit cooler cover
B	Drain port
C	Drain hose

10.6.1 Remove the Unit Cooler Cover



WARNING Disconnect the refrigerator from AC power when removing the unit cooler.



CAUTION The condensate evaporator and water evaporation tray are hot.

- 1 Disconnect the refrigerator from AC power. Remove one battery from the monitoring system backup battery holder.
- 2 Remove top drawer, basket, or shelf from the chamber.
- 3 On the back of the chamber, peel putty back to expose drain hose (C).
- 4 Remove drain hose from unit cooler drain port (B).
 - a Pull drain hose downward to separate from unit cooler.
 - b Twist drain hose while pulling to assist in removal.
- 5 Push the drain hose (C) out through rear of chamber.
- 6 Remove the unit cooler cover.
 - a Hold unit cooler cover in place to prevent it from dropping.
 - b Use the socket wrench to remove four screws securing the unit cooler cover.
 - c Carefully lower unit cooler cover to avoid damage to the fan wiring.

10.6.2**Install the Unit Cooler Cover**

- 1 Verify unit cooler wiring is connected and routed correctly.
 - a Wiring should be routed above copper tube inside the unit cooler.
 - b Reconnect wires if they have separated.
- 2 Attach unit cooler cover.
 - a Lift unit cooler cover into place.
 - b Front edge of the cover should be behind the unit cooler case.
 - c Use the socket wrench to install four screws to secure the unit cooler cover.
- 3 Insert the drain hose through hole in the refrigerator.
 - a Push drain hose upward, toward the unit cooler drain port.
 - b In the chamber, push drain hose onto unit cooler drain port.
- 4 On the back of the chamber, press putty around the drain hose.
- 5 Reinstall the top drawer, shelf, or basket.
- 6 Reinstall the battery in the monitoring system backup battery holder. Reconnect the refrigerator to AC power.
- 7 Press the **Mute** button to disable the high temperature alarm while refrigerator reaches operating temperature.

10.7**Supplies**

Refrigerant: non-CFC, R-134A

Chart paper: 220366 (52 sheets)

Glycerin solution: 400922-1

Fluorescent lamp: T5, 13 W

Monitoring system batteries: (6) 1.5 V, D-cell non-rechargeable alkaline batteries (or equivalent): 715031

Chart recorder battery (optional): (1) 9 V non-rechargeable alkaline (or equivalent): 120218

11 Troubleshooting



- CAUTION**
- ▶ Review all safety instructions prior to troubleshooting. Refer to chapter 2 (Safety).
 - ▶ Troubleshooting should only be performed by trained refrigeration technicians.

11.1 General Operation Problems

Problem	Possible Cause	Action
Drawer or basket does not slide easily.	Drawer slide is faulty.	▶ Confirm the slide is operating correctly. Replace if necessary.
	Debris in the drawer slides.	▶ Pull the drawer or basket out and confirm the slides are free of debris. Clean if necessary.
	Drawer slides are not lubricated.	▶ Using a lightweight oil, lubricate the bearings in the slides.
	Drawer or basket is misaligned or not level.	▶ Confirm both slides for the drawer or basket are mounted at the same height.
Door does not open easily.	Debris in the hinges.	▶ Confirm the hinges are free of debris. Clean the hinges if necessary.
	Door hinges are not lubricated.	▶ Using a general-purpose grease, lubricate the pivots in the hinges.
	Hinge cam is faulty.	▶ Confirm the hinge cam is not damaged. Replace if necessary.
Monitor display is hard to read.	Screen contrast is set too low.	▶ Change the screen contrast.
Alarm monitor is not responding.	Digital electronics are locked because of an interruption in power.	▶ Reset the monitoring system.
Chamber temperature meets an alarm condition, but the appropriate temperature alarm is not active.	Temperature alarm setpoint was changed.	▶ Check the current setpoints for the temperature alarms. Change the setpoints if necessary.

11.2 Chamber Temperature Problems

Problem	Possible Cause	Action
Chamber temperature displayed is higher or lower than the actual temperature.	Connection for the chamber temperature probe is loose.	▶ Test the probe connection. Secure the connection if necessary.
	Temperature probe wiring is an open circuit.	▶ Check the continuity of the probe wiring. Replace the probe if necessary.
	Probe bottles are empty, or solution is too low.	▶ Check the level of product simulation solution in the bottles. Refill the bottles if necessary.
	Monitor is not calibrated.	▶ Confirm the upper temperature probe is reading correctly. Calibrate the probe if necessary.
	Digital electronics are locked because of an interruption in power.	▶ Reset the monitoring system.
	A component is faulty or internal connections are loose.	▶ Contact Helmer Technical Service.
Chamber temperature does not stabilize at the refrigerator setpoint.	Compressor starting relay is faulty.	▶ Confirm the relay is operating correctly. Replace the relay if necessary.
	Temperature controller is faulty.	▶ Confirm the temperature controller is operating correctly. Replace it if necessary.
	Condensing unit fan is not running.	▶ Check the condensing unit fan connections. Replace the fan motor if necessary.
	Unit cooler fan is not running.	▶ Check the voltage to the fan when door switch is activated. Replace the fan motor or door switch if necessary.
	Compressor motor has seized.	▶ Replace the compressor.
	Temperature control probe is faulty.	▶ Confirm the probe is providing resistance in the range of 98 Ω to 110 Ω . Replace the probe if necessary.
	Refrigerant level is too low.	▶ Check the refrigeration lines for leaks and repair them if necessary.
		▶ Check the refrigerant level. Recharge the refrigerant if necessary.
	Condenser grill is dirty.	▶ Check the condenser grill. Clean it if necessary.
	Circulation at the top of the chamber is not adequate.	▶ Check if there are any items that may obstruct air flow and remove them if necessary.
	Ambient air temperature is too high.	▶ Confirm the refrigerator is placed appropriately. Refer to the operation manual.
	A component is faulty or internal connections are loose.	▶ Contact Helmer Technical Service.
Probe bottle is empty, or solution is too low.	▶ Check the level of product simulation solution in the bottle. Refill the bottles if necessary.	

Problem	Possible Cause	Action
Compressor runs continuously.	Refrigerator setpoint is set too low.	▶ Confirm the setpoint is set within the operating range. Change the setpoint if necessary.
	Temperature control probe is faulty.	▶ Confirm the probe is providing resistance in the range of 98 Ω to 110 Ω. Replace the probe if necessary.
	Temperature controller is faulty.	▶ Confirm the temperature controller is operating correctly. Replace the board(s) if necessary.
	Compressor starting relay is faulty.	▶ Confirm the relay is operating correctly. Replace it if necessary.
	Defrost timer is faulty (ILR and iPR models).	▶ Replace the defrost timer.

11.3

Alarm Activation Problems

Problem	Possible Cause	Action
Refrigerator is in an alarm condition, but alarms are not audible.	Alarm system is faulty.	▶ Confirm the circuit board and line connections are functioning correctly.
	Control board is faulty.	▶ Replace control parts with those that are included in the control and display board kit.
	Alarm buzzer is faulty.	▶ Replace the alarm buzzer.
	Audible alarms have been muted.	▶ Verify audible alarms are not muted. If the time remaining on the MUTE timer is greater than 5 minutes, change the MUTE timer value to 5 minutes and wait until the timer resets.
	A component is faulty or internal connections are loose.	▶ Contact Helmer Technical Service.
Refrigerator meets an alarm condition, but the appropriate alarm is not active.	Control board is faulty.	▶ Replace control parts with those that are included in the control and display board kit.
	Alarm setpoint was changed.	▶ Check the current setpoints for the alarms. Change the setpoints if necessary.
	A component is faulty or internal connections are loose.	▶ Contact Helmer Technical Service.

Problem	Possible Cause	Action
High Temperature alarm activates when the door is opened, then clears shortly after the door is closed.	Chamber temperature probe connection is loose.	▶ Test the probe connections. Secure the connections if necessary.
	Chamber temperature probe is faulty.	▶ Test the probe. Replace the probe if necessary.
	Unit cooler fan continues to run while the door is open.	▶ Test the door switch and unit cooler fan connections. Secure the connections if necessary. Replace the door switch or fan motor if necessary.
	Probe bottles are empty.	▶ Check level of product simulation solution in the bottles. Refill bottles if needed.
	High temperature alarm setpoint is set too low.	▶ Check the setpoint. Change the setpoint if necessary.
	A component is faulty or internal connections are loose.	▶ Contact Helmer Technical Service.
Refrigerator is connected to power, but the AC Power Failure alarm is active.	Outlet connection is faulty.	▶ Verify power at the outlet. Repair the original outlet or connect to a different outlet if necessary.
	Power cord is faulty.	▶ Confirm the power cord is connected securely. Secure the power cord if necessary.
	Power supply board is faulty.	▶ Replace the power supply board.
	Circuit breaker was tripped (230 V models).	▶ Confirm the circuit breaker is seated. Push the circuit breaker to reset it if necessary.
	A component is faulty or internal connections are loose.	▶ Contact Helmer Technical Service.
Door Open alarm is activating sporadically.	Door(s) not closing completely.	▶ Confirm the hinge cams are not damaged. Replace the hinge cams if necessary.
	Door(s) closing but not sealing completely.	▶ Confirm the door gasket seals completely. Replace the door gasket if necessary.
	Door switch connection(s) is faulty.	▶ Test the switch connections. Secure the connections if necessary.
	One or both door switches are faulty.	▶ Replace the door switch(s).
	Control board is faulty.	▶ Replace control parts with those that are included in the control and display board kit.
	Door Ajar Timeout is set to zero, causing the alarm to activate immediately when the door is opened.	▶ Check the current setpoint for the Door Ajar alarm. Change the setpoint if necessary.

Problem	Possible Cause	Action
All alarms are activating sporadically.	Alarm system is faulty.	▶ Confirm the circuit board and line connections are functioning correctly.
	A component is faulty or internal connections are loose.	▶ Contact Helmer Technical Service.
	Control board is faulty.	▶ Replace control parts with those that are included in the control and display board kit.
Condenser alarm is active.	Refrigerant level is too low.	▶ Check refrigeration lines for leaks and repair if necessary. Check the refrigerant level. Recharge refrigerant if necessary.
	Connections for the condenser temperature probe are loose.	▶ Test the probe connections. Secure the connections if necessary.
	Condenser temperature probe is faulty.	▶ Test the probe. Replace the probe if necessary.
	Condenser probe is not calibrated.	▶ Confirm the condenser probe is reading correctly. Calibrate the probe if necessary.
	Compressor is overheating due to lack of airflow.	▶ Check the condenser grill. Clean it if necessary. ▶ Confirm the refrigerator is placed appropriately. Refer to the operation manual.
	Condenser alarm setpoint is too low.	▶ Confirm the alarm setpoint is set at the appropriate value.
	A component is faulty or internal connections are loose.	▶ Contact Helmer Technical Service.
	An alarm activated, but the temperature recorded at activation does not match the alarm setpoint.	Monitor is not calibrated.
Temperature changed slightly around the time of activation.		▶ No action needed.
No Battery alarm is activating sporadically.	Battery voltage level on the backup batteries for the monitoring system is low.	▶ Replace the backup batteries for the monitoring system.

11.4 Testing Problems

Problem	Possible Cause	Action
The automatic temperature tests do not work.	Upper chamber temperature probe connection is loose.	▶ Test the probe connection. Secure the connection if necessary.
	Upper chamber temperature probe is faulty.	▶ Test the probe. Replace the probe if necessary.
	Control board is faulty.	▶ Replace parts with those that are included in the control and display board kit.
	High Alarm setpoint is set significantly higher than the default value, or the Low Alarm setpoint is set significantly lower than the default value.	▶ Confirm the alarm setpoints are set at the appropriate values. ▶ Test the temperature alarms manually.

11.5 Condensation Problems

Problem	Possible Cause	Action
Excessive water in the water evaporation tray.	Heater in the evaporation tray is faulty.	▶ Confirm the heater is hot and is drawing the appropriate current. ▶ For 115 V refrigerators, the current should be approximately 0.43 A to 0.55 A. ▶ For 230 V refrigerators, the current should be approximately 0.21 A to 0.35 A.
	Humid air is entering the chamber.	▶ Confirm the refrigerator is level, and the doors are aligned, closing tightly, and sealing correctly. ▶ Contact Helmer Technical Service to correct issues as necessary.
Excessive water in the chamber.	Humid air is entering the chamber.	▶ Confirm the refrigerator is level, and the doors are aligned, closing tightly, and sealing correctly. Correct issues as necessary.
	Connection between the unit cooler and the drain tube is loose.	▶ Confirm the connection is secure. Tighten the connection if necessary.
	Defrost timer is faulty.	▶ Replace the defrost timer.
	Drain line is plugged.	▶ Confirm the drain tube is free of debris. Remove debris if necessary.
Excessive humidity on the doors.	Humid air is entering the chamber.	▶ Confirm the refrigerator is level, and the doors are aligned, closing tightly, and sealing correctly. Correct issues as necessary.
	Relative humidity around the refrigerator is too high.	▶ Confirm the refrigerator is placed properly. Refer to the operation manual.

12 Parts



NOTICE

- ▶ Before replacing parts, protect items in refrigerator from extended exposure to adverse temperature.
- ▶ Allow refrigerator temperature to stabilize at setpoint after replacing parts or after extended door opening.

12.1 Front

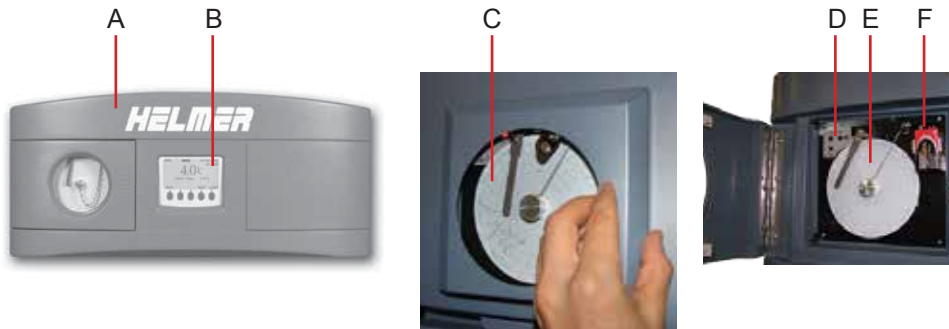

Label	Description	Part Number	Schematic Label
A	Bezel with chart recorder door	iB models (except 111 models): 800112-2	-
B	i.Center display	Refer to subsequent section(s) for part numbers	K
C	Chart recorder and chart recorder door	iB111 and iHB models: 400409-2	X
D	Chart recorder	400409-3	X
E	Chart paper	220366 (package of 52 sheets)	-
F	Chart recorder backup battery (9 V alkaline, non-rechargeable)	120218	AD
Not shown	Bezel without chart recorder door	iLR and iPR models (except 111 models): 800112-1	-
	Bezel without temperature monitor or chart recorder door	800112-4	-
	Caster (swivel with brake)	Serial number 974891 and earlier: 220380 Serial number 947892 and later: 220467	-

12.1.1 Display

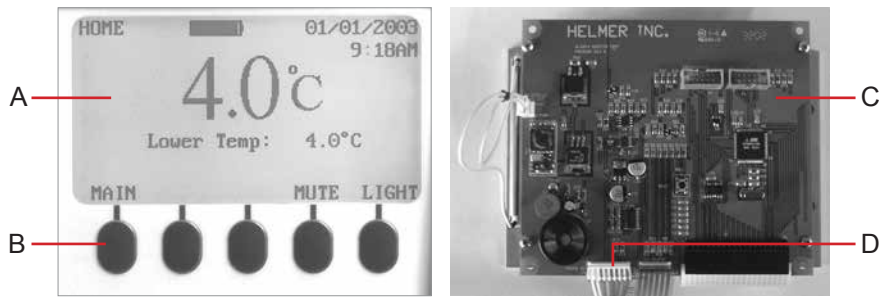

Left: Display assembly showing LCD and touchpad. Right: Display board.

Label	Description	Part Number	Schematic Label
A	LCD board	120452	K
B	Touchpad	320722-1	K
C	Display board	Included in the control and display board kit	K
D	Interface cable	400502-1	AF
Not shown	Display assembly	400509-1 (Includes LCD board and touchpad)	K



NOTICE The i.Center display assembly is sensitive to static electricity and can be damaged by electrostatic discharge. Use proper ESD precautions when handling the display assembly.

NOTE Although the LCD display and touchpad may be replaced individually, Helmer recommends replacing the entire display assembly.

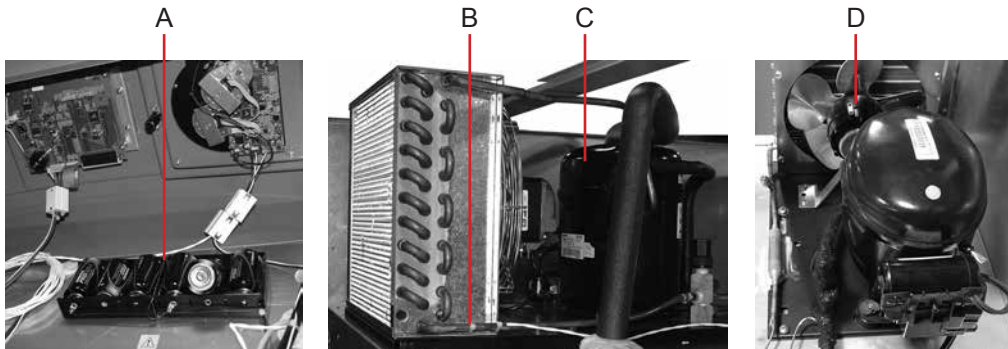

Top features.

Label	Description	Part Number	Schematic Label
A	Monitoring backup batteries	715031	AE
B	Condenser probe	400674-1 (probe with connector)	AC
C	Compressor unit	Contact Helmer	A
D	Condensing unit fan motor	Contact Helmer	U

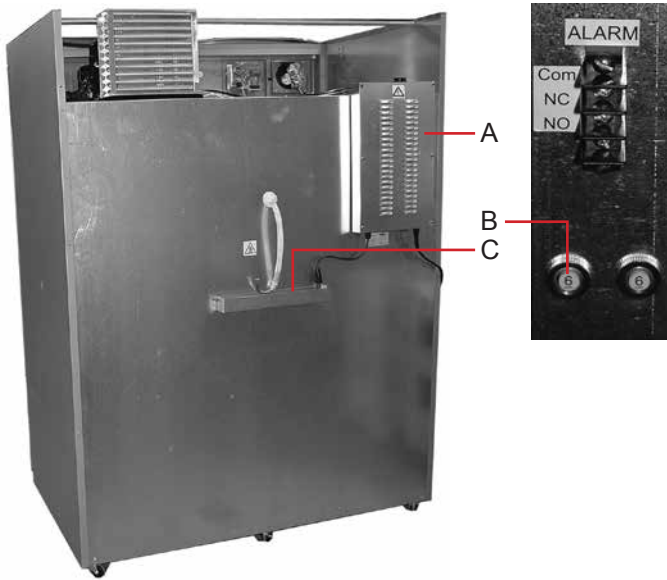

Rear features.

Label	Description	Part Number	Schematic Label
A	Electrical box	Refer to subsequent section(s) for part numbers	-
B	Circuit breaker, 6 A	Single-door 230 V models: 120429	P
	Circuit breaker, 7 A	Double-door 230 V models: 120428	P
C	Condensate evaporator kit (Includes the condensate evaporator and water evaporation tray)	115 V: 111 models: 400791-1 120, 125, 245, and 256 models: 400790-1 230 V: 111 models: 400791-2 120, 125, 245, and 256 models: 400790-2	J

12.3.1 Electrical Box

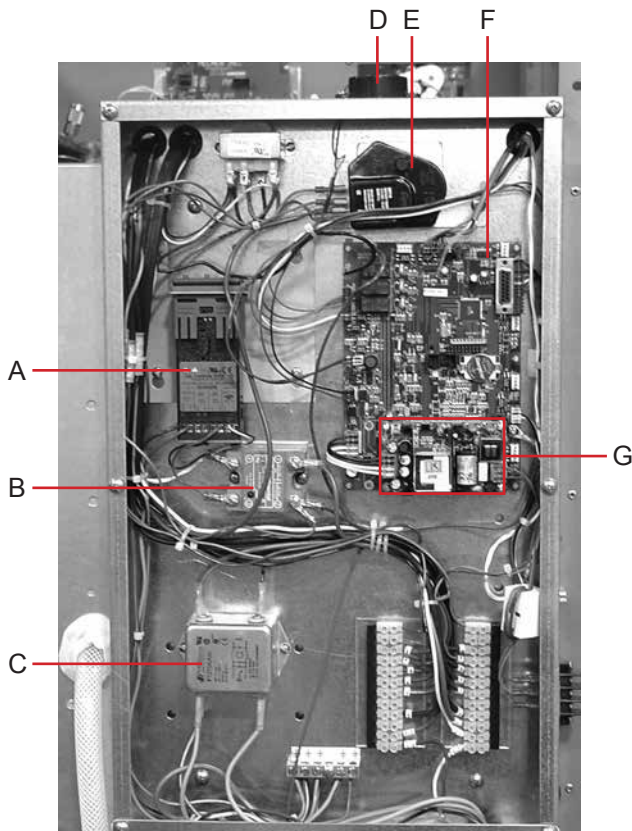

Electrical box features (iLR120 model shown).

Label	Description	Part Number	Schematic Label
A	Temperature controller (programmed)	iB models: 400422-1 iLR111 and iPR111 models: 400422-2 iLR and iPR 120, 125, 245, and 256 models: 400422-1	B
B	Compressor relay	120426	AA
C	Power line filter	120400	AK
D	Alarm buzzer	120457	D
E	Defrost timer (iLR and iPR models only)	111 models: 120556 120, 125, 245, and 245 models: 800127-1	F
F	Control board	Included in the control and display board kit	E
G	Power supply board	400633-1	AH
Not shown	Control and display board kit	400651-1 (Includes control board, display board, power supply board, and interface cable)	K,E

12.4

Interior

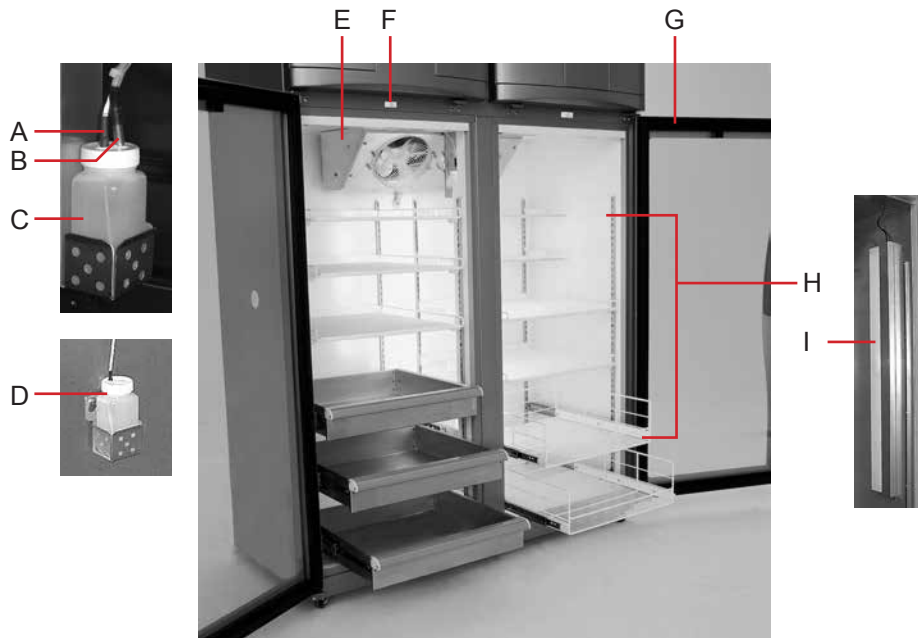

Interior features.

Label	Description	Part Number	Schematic Label
A	Chart recorder probe	400855-1	AI
B	Upper chamber probe	400510-1	AB
C	Probe bottle and glycerin kit	400922-1	-
D	Lower chamber probe	800117-1 (except 111 model)	N
E	Unit cooler	Refer to subsequent section(s) for part numbers	AG
F	Door switch	120380	I
G	Door	Refer to subsequent section(s) for part numbers	-
H	Storage parts	Refer to subsequent section(s) for part numbers	-
I	Lamp assemblies	Refer to subsequent section(s) for part numbers	M

12.4.1 Lighting



CAUTION Disconnect refrigerator from power when replacing lamps.

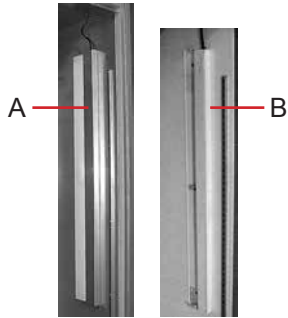

Light features.

Label	Description	Part Number	Schematic Label
A	Light assembly (models with stainless steel interior)	115 V: 400508-1 230 V: 400508-2	M
B	Light assembly (models with powder-coated interior)	115 V: 400507-2 230 V: 400507-1	M
Not shown	Light bulb	120409	-

12.4.2 Unit Cooler

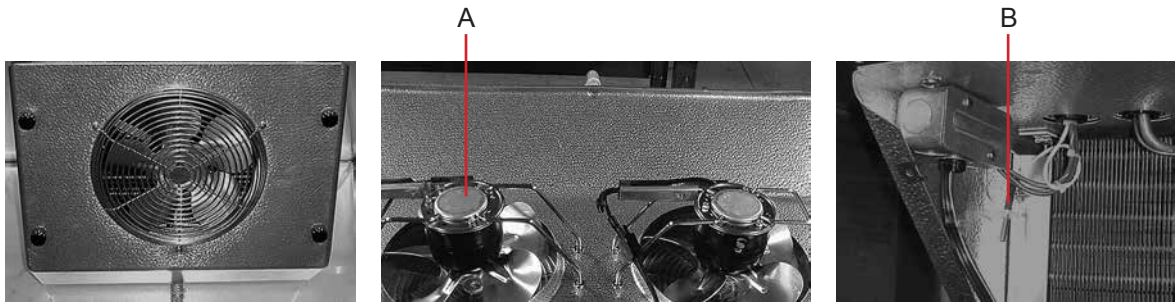

Left: Unit cooler (single-door model shown). Center and right: Unit cooler parts.

Label	Description	Part Number	Schematic Label
A	Unit cooler fan motor	115 V 111 models: 120540 120 and 125 models: 120411 245 and 256 models (one fan): 120587 245 and 256 models (two fans): 120410 230 V 111 models: 120560 120 and 125 models: 120415 245 and 256 models (one fan): 120588 245 and 256 models (two fans): 120545	H
B	Temperature control probe	400854-1	G

12.4.3 Storage



Storage features.

Label	Description	Part Number
A	Half shelf (includes hardware)	120, 125, 245, 256 models: 400413-1
B	Full shelf (includes hardware)	111 models: 400414-3 120 and 245 models: 400414-1 125 and 256 models: 400414-2
C	Roll out basket assembly (includes 2 slides, and hardware)	111 models: 400751-1 120 and 245 models: 400415-1 125 and 256 models: 400415-2
D	Drawer assembly (includes 2 slides and hardware)	111 model with glass door: 400752-1 120 and 245 models with glass doors: 400370-1 125 and 256 models with glass doors: 400370-2 111 models with solid door: 400752-2 120 and 245 models with solid doors: 400370-3 125 and 256 models with solid doors: 400370-4
Not shown	Slide assembly (includes 2 slides)	111 models: 400753-1 120 and 245 models: 400714-1 125 and 256 models: 400714-2
	Pole mast for chromatography (iLR model with chromatography option)	400478-1

12.4.4 Door and Hinge



Door and hinge parts.

Label	Description	Part Number
A	Door lock	220374
B	Door handle pad	320684-1
C	Hinge bearing	220375
D	Upper hinge bracket	Right hinge: 400376-1 Left hinge: 400376-2
E	Door gasket	111 models: 321082-1 120, 125, 245, and 256 models: 320726-1
F	Hinge cam	320742-1
G	Door stop	320763-1
H	Lower hinge bracket	Right hinge: 400377-1 Left hinge: 400377-2

13 Schematics

13.1 iB and iHB Models; 11, 20, 25, 45, 56 Cubic Feet

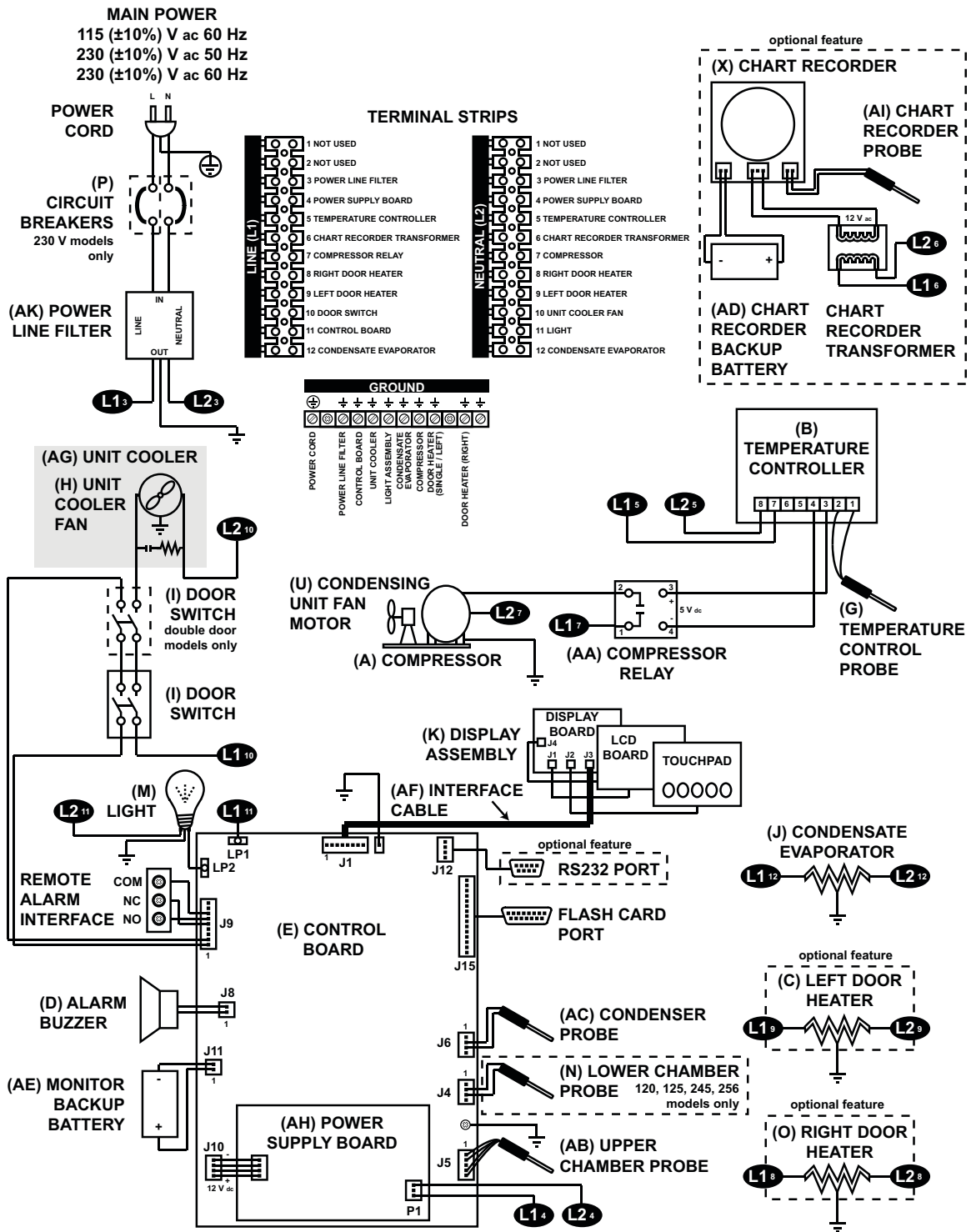

13.2 iLR, iPR Models; 11 Cubic Feet

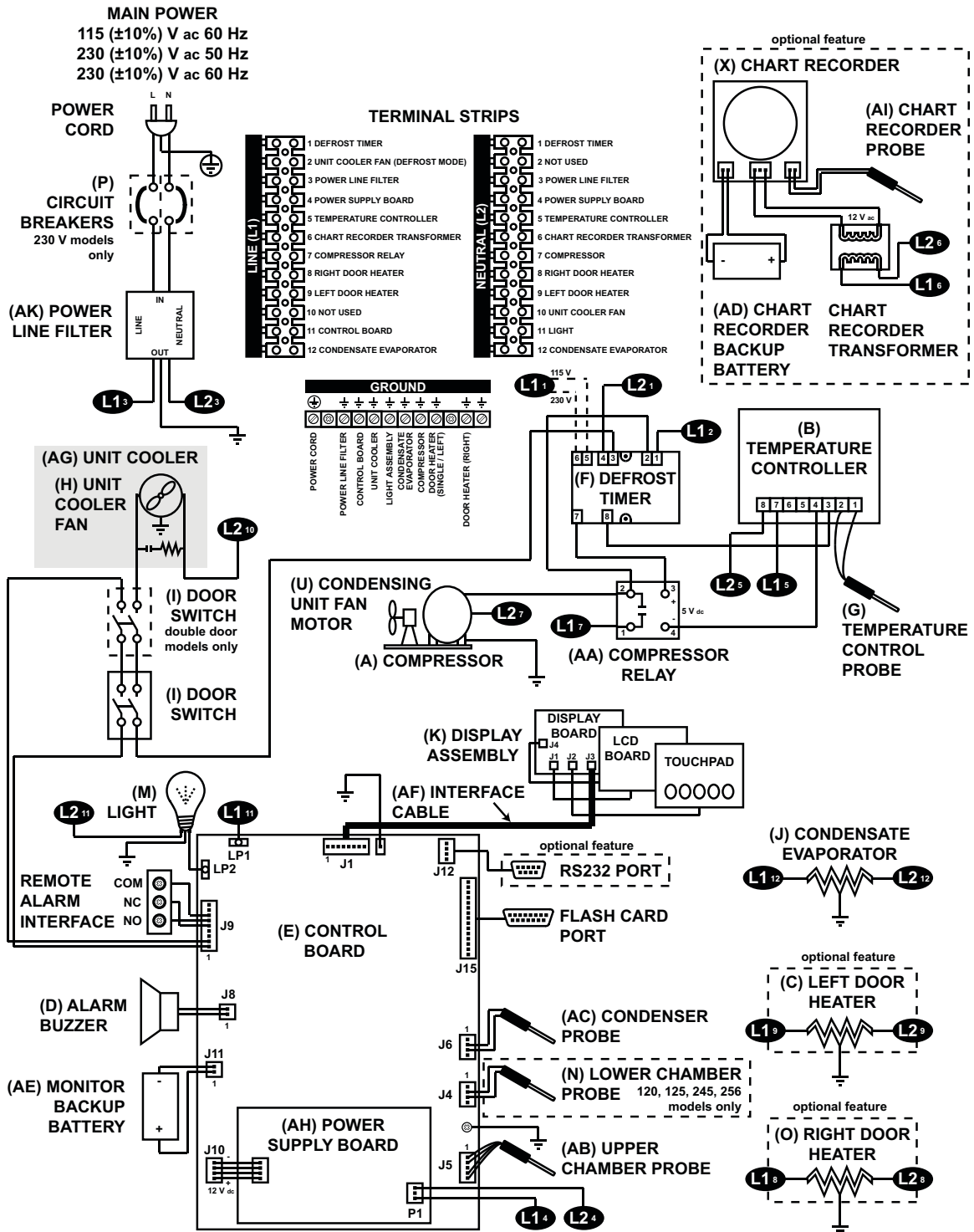

13.3 iLR and iPR Models; 20, 25, 45, and 56 Cubic Feet

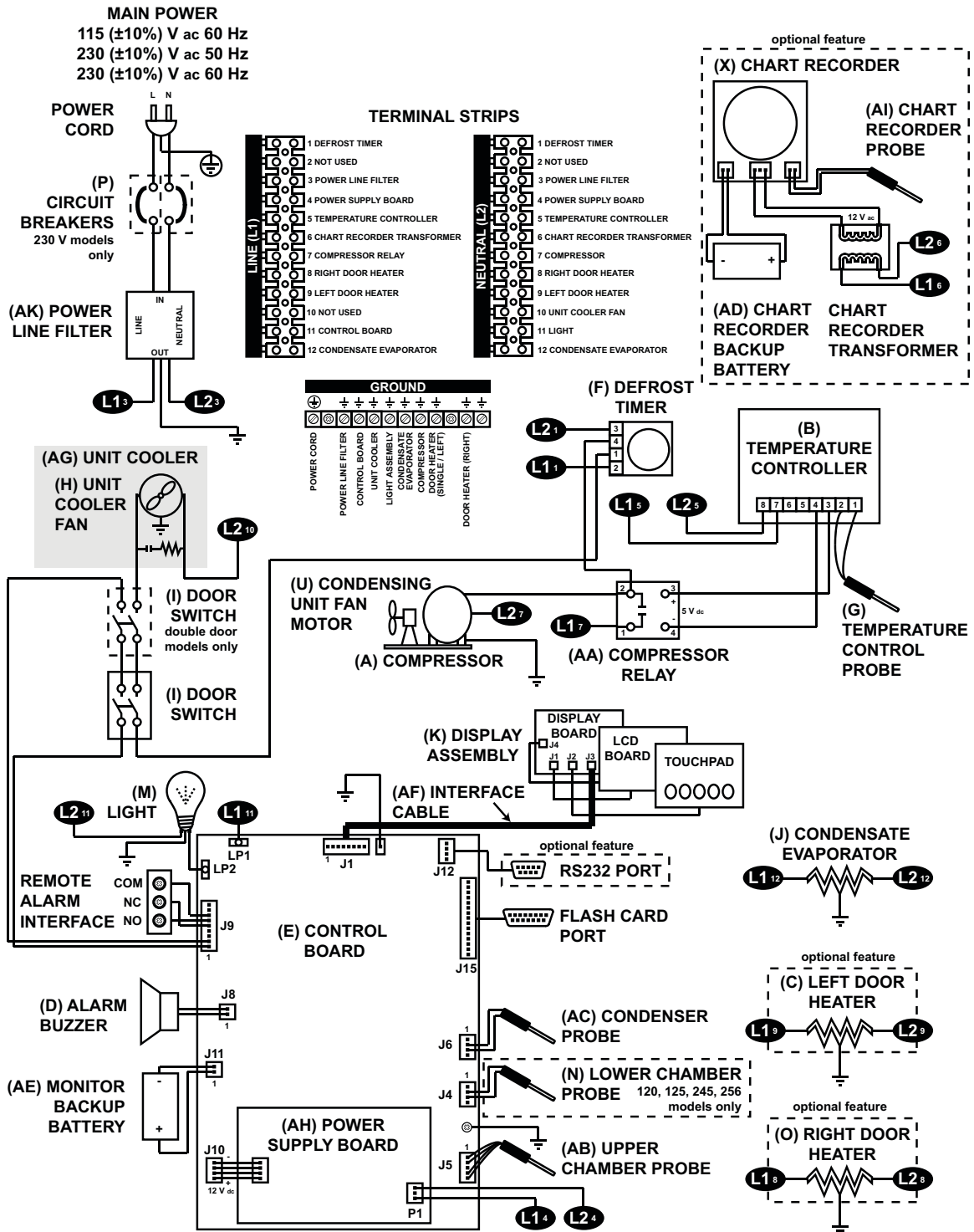

14 **i.Center Screen Reference****HOME** screen**MAIN** button**MAIN** screen**MUTE** button (changes mute timer)**LIGHT** button (turns light on or off)**MAIN** screen**Event Log** option(Press the **SELECT** button)**EVENT LOG** screen**System Alarm Test & Status** option**SYSTEM ALARM TEST & STATUS** screen**Edit Configuration** option

(Enter the password)

CONFIGURATION screen**View Configuration** option**VIEW CONFIGURATION** screen**Product/Company Information** option**INFORMATION** screen**i.Help Index** option**i.Help** screen**EVENT LOG** screen**EVENT LOG DETAIL** screen**SYSTEM ALARM TEST & STATUS** screen**Start High Alarm Auto Test** option**Start Low Alarm Auto Test** option**Cancel High or Low Test** option**Chart Paper Days Left or Chart Paper Timer** display**Door Status** display**Condenser Temp** display**CONFIGURATION** screen**Set Date & Time** option**SET DATE & TIME** screen**System Options** option**SYSTEM OPTIONS** screen**Alarm Setpoints** option**SET ALARM SETPOINT** screen**Temperature Calibration** option**TEMPERATURE CALIBRATION** screen**Factory Default Settings** option**FACTORY DEFAULT SETTINGS** screen**Change Password** option

(Enter a new password)

SYSTEM OPTIONS screen

- Language option
- Date Format option
- Alarm Volume option
- Alarm Pulse option
- Temperature Units option
- Chart Paper Timer option

SET ALARM SETPOINT screen

- High Alarm Setpoint option
- Low Alarm Setpoint option
- Cond. Alarm Setpoint option
- Door Ajar Timeout option
- Power Failure Timeout option
- Temperature Graph option

TEMPERATURE CALIBRATION screen

- Select Temp Probe option
- Temperature option

VIEW CONFIGURATION screen

- Clock Mode display
- Date Format display
- Door Ajar Timeout display
- Pwr Failure Timeout display
- High Alarm Setpoint display
- Low Alarm Setpoint display
- Cond. Alarm Setpoint display
- Alarm Volume display
- Alarm Pulse display
- Chart Paper Days Left or Chart Paper Timer display
- Temperature Graph display

Section III: Horizon Series™ - Blood Bank Models

NOTE This section applies to HB models.

15 Product Configuration

15.1 Install Battery for Backup Power

The monitoring system has a battery system, enabling a period of continuous operation if power is lost.

NOTE The monitoring system will not start on battery power alone. If the refrigerator was previously not connected to AC power and the batteries are installed, the monitoring system will not run on battery power.

Battery life varies by manufacturer as well as voltage level remaining. Providing full power is available and no battery-related alarms are active, backup power for the monitoring system is available for up to two hours.



NOTICE When installing replacement batteries, use only batteries which meets the specifications outlined in chapter 18.6 (Supplies).

The batteries are located on the top of the refrigerator, behind the monitoring system. For 111 models, a service cover covers the components and an access panel provides access to the monitoring system backup batteries.

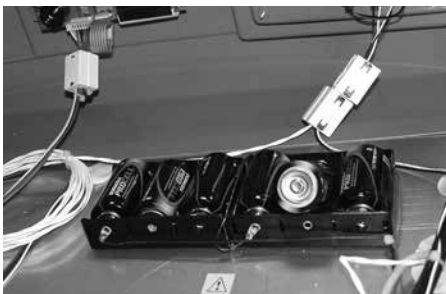

Monitoring system backup batteries.

Five batteries are installed and one battery is included in the accessory package. Install the sixth battery to provide power to the monitoring system in the event of an AC power failure.

15.2 External Monitoring Devices



- CAUTION**
- ▶ The interface on the remote alarm monitoring system is intended for connection to the end user's central alarm system(s) that uses normally-open or normally-closed dry contacts.
 - ▶ If an external power supply exceeding 30 V (RMS) or 60 V (DC) is connected to the remote alarm monitoring system's circuit, the remote alarm will not function properly; may be damaged; or may result in injury to the user.

NOTE In the event of a power failure, the power failure alarm condition is transmitted through the remote alarm contacts.

The remote alarm interface is a relay switch with three terminals:

- ▶ Common (COM)
- ▶ Normally Open (NO)
- ▶ Normally Closed (NC)

Terminals are dry contacts and do not supply voltage. Interface circuit is either normally open or normally closed, depending on terminals used. Requirements for your alarm system determine which alarm wires must connect to terminals.

- ▶ 0.5 A at 30 V (RMS): 1.0 A at 24 V (DC)

15.2.1 Connect to Remote Alarm Interface

- 1 Disconnect AC power from the refrigerator. Remove one battery from the monitoring system backup battery holder.
- 2 On back of refrigerator, locate the remote alarm terminals.
- 3 Connect remote alarm wires to appropriate terminals, according to requirements for your alarm system.
- 4 Use a cable tie to relieve strain on alarm wires (as necessary).
- 5 Reinstall the battery in the monitoring system backup battery holder. Reconnect the refrigerator to AC power.
- 6 Touch **MUTE** to disable the high temperature alarm while refrigerator reaches operating temperature.



Storage features.



CAUTION

- ▶ Keep hands away from pinch points when closing the door.
- ▶ Before moving drawers, ensure they are completely empty for safe lifting.
- ▶ Maximum basket, drawer, or shelf load is 100 lbs (46 kg).



NOTICE

Before moving storage components, protect stored items in refrigerator from extended exposure to adverse temperature.

Remove a drawer or basket:

- 1 Pull drawer or basket out until it stops.
- 2 On the right rail, locate the release tab and press downward.
- 3 While holding the right release tab downward, locate the release tab on the left rail and press upward.
- 4 Pull drawer or basket free of the slides.

Install a drawer or basket:

- 1 Align end guides on drawer or basket with the slides.
- 2 Gently push drawer or basket into chamber until it stops.
- 3 Pull drawer or basket out until it stops; check for smooth operation.

Remove a shelf:

- 1 With one hand, lift front edge of the shelf from the front brackets.
- 2 With the other hand, reach under the shelf and bump rear edge of the shelf upward to disengage rear brackets.

Install a shelf:

- 1 Insert shelf into chamber, placing it on brackets.
- 2 Gently bump rear edge of the shelf downward to engage brackets.
- 3 Pulling shelf forward gently; shelf should not disengage from rear brackets.

15.4 Move Slides and Brackets

Remove drawer slides:

- 1 Using a screwdriver, remove front bracket retainers.
- 2 Tap front brackets upward to disengage standards.
- 3 Remove slides from standards.

Install drawer slides:

- 1 Insert slides into standard at appropriate height.
- 2 Tap front brackets downward to engage standards.
- 3 Using a screwdriver, install front bracket retainers.

Remove shelf brackets:

- 1 Using a screwdriver, remove front bracket retainers.
- 2 Tap front brackets upward to disengage standards.
- 3 Remove front brackets from standards.

Install shelf brackets:

- 1 Insert front brackets into standard at appropriate height.
- 2 Tap front brackets downward to engage standards.
- 3 Using a screwdriver, install front bracket retainers.

15.5 Optional Adapter Kits for Medication Dispensing Locks

Contact Helmer Technical Service or your distributor for service documentation pertaining to medication dispensing locks.

16 Temperature Monitor Settings

16.1 Home Screen

The HOME screen appears when:

- ▶ The **HOME** button is pressed from any other screen
- ▶ There is no interaction for two minutes on any screen other than those used to enter a password



HOME screen on the monitoring system.

Label	Description
A	Screen name
B	Chamber temperature display
C	Button labels
D	Buttons
E	Date and time display

16.1.1 Home Screen Functions

NOTE Refer to chapter 22 (Horizon Series Screen Reference) for a complete list of screens in the Horizon Series monitoring system.

- ▶ View current temperature readings
- ▶ View the current time and date
- ▶ View detailed information about current or previous alarm events
- ▶ View active alarms
- ▶ Mute audible alarms
- ▶ Adjust contrast
- ▶ Access Main screen to view and change settings

16.2 Main Screen

The Main screen displays functional options that allow access to all other screens in the system.



MAIN screen functional options.

Option	Function
Edit Configuration (password required)	<ul style="list-style-type: none"> ▶ Change the language used for text ▶ Change date and time information ▶ Change temperature units ▶ Change the volume and pattern for audible alarms ▶ Enable or disable the chart paper timer ▶ Change alarm-related setpoints and timers ▶ Calibrate the temperature probe reading ▶ Change some settings to the factory default values ▶ Change the password, preventing unauthorized changes
View Configuration	<ul style="list-style-type: none"> ▶ View the date and time formats ▶ View alarm-related setpoints and timers ▶ View the volume and pattern for audible alarms ▶ View the setting for the chart paper timer ▶ View the settings for temperature and time alarms
Product/Company Information	<ul style="list-style-type: none"> ▶ View the software versions for control and display components of the monitoring system ▶ View information to contact Helmer

16.3 Change Configuration Password

The default password is 1234. A new password must use four digits, ranging from 1 to 5.

Change the password:

- 1 On the HOME screen, press the **MAIN** button.
- 2 Press the **DOWN** button to select Edit Configuration. Press the **SELECT** button.
- 3 Enter the password when prompted.
- 4 Press the **DOWN** button to select Change Password. Press the **SELECT** button.
- 5 Enter the new password, then re-enter the new password when prompted.
 - ▶ If password entries match, the “update” message is displayed.
 - ▶ If password entries do not match, the “incorrect match” message is displayed. Repeat the procedure to change the password.

16.4 Calibrate Chamber Temperature Probe

Verify the temperature probe is reading chamber temperature correctly by comparing the chamber probe reading to temperature read by an independent thermometer. If the chamber temperature probe is not reading correctly, change the value displayed on the temperature monitoring system.

NOTE If the variance is within acceptable limits for your organization, changing probe settings is optional.

- ▶ Default setting for chamber temperature is 4.0 °C
- ▶ Value is factory-preset

Obtain:

- ▶ Independent thermometer, calibrated and traceable per national standards

Measure the chamber temperature:

- 1 Remove the probe from the probe bottle.
- 2 Unscrew the cap from the bottle.
- 3 Insert the thermometer and temperature probe in the bottle. The probe and thermometer should be immersed at least 2” (50 mm).
- 4 Close the door and allow the chamber temperature to stabilize for 10 minutes.
- 5 Observe and note the thermometer temperature.

EXAMPLE

- ▶ Measured temperature (at the probe bottle) is 4.0 °C
- ▶ Displayed temperature is 4.5 °C
- ▶ Change displayed temperature to 4.0 °C

Enter the new calibration value:

- 1 On the HOME screen, press the **MAIN** button.
- 2 Press the **DOWN** button to highlight Edit Configuration. Press the **SELECT** button.
- 3 Enter the password when prompted.
- 4 Press the **DOWN** button to highlight Temperature Calibration. Press the **SELECT** button.
 - a The Upper Probe option is displayed and the Temperature option is highlighted.
 - b Press the **INC** or **DEC** buttons to change the displayed value to match the value measured by the independent thermometer.

- 5 Press the **DOWN** button to highlight Store Calibration.
 - a To save the new value, press the **ENTER** button. The “Calibration Memorized” message appears. New settings are saved.
 - b To discard the new value, press the **BACK** button to return to the Edit Configuration screen, or press the **HOME** button to exit. New settings are not saved.
- 6 Remove thermometer and probe from bottle.
- 7 Replace the probe in probe bottle.
- 8 Replace bottle cap, ensuring a tight fit.
- 9 Place the probe in bottle, immersing at least 2” (50 mm).

NOTE

- ▶ The current temperature displayed by the monitoring system may change so that it no longer matches the new probe calibration value. This is normal.
- ▶ If a new probe value is entered but not saved, the new value will appear when the calibration setting for the probe is viewed. This is normal.

16.5 Factory Default Settings

Settings listed below may be simultaneously returned to factory default values.

NOTE The factory default settings may not be the same as the settings that were factory-calibrated before the refrigerator was shipped.

Setting	Restored Value
High Alarm Setpoint	5.5 °C
Low Alarm Setpoint	1.5 °C
Door Ajar Timeout	3 minutes
Power Failure Timeout	3 minutes
Chart Paper Timer	6.5 days

NOTE Unless your organization requires the Low Alarm Setpoint to be at the factory default level of 1.5 °C, it will be necessary to increase the setpoint to 2.0 °C after restoring factory defaults.

16.6 Restore Factory Default Settings

Restore settings:

- 1 Press the **MAIN** button.
- 2 Press the **DOWN** button to highlight Edit Configuration. Press the **SELECT** button.
- 3 Enter the password when prompted.
- 4 Press the **DOWN** button to highlight Factory Default Settings. Press the **SELECT** button.
- 5 Do one of the following:
 - ▶ Press the **ENTER** button. Factory default settings are restored.
 - ▶ Press the **BACK** button. Factory default settings are not restored.

16.7 Alarm Settings

The following alarm settings may be changed by the operator. The setpoint for temperature alarms may be changed (where applicable), as well as the time delay between when the alarm condition commences and when the visual and audible alarms are initiated.

16.7.1 Alarm Volume

The alarm volume can be changed. The Alarm Volume controls volume for all audible alarms.

- ▶ Default setting is 10
- ▶ Setting can be changed from 1 to 10
- ▶ 1 is the quietest setting; 10 is the loudest setting

Change the alarm volume:

- 1 Press the **MAIN** button.
- 2 Press the **DOWN** button to highlight Edit Configuration. Press the **SELECT** button.
- 3 Enter the password when prompted.
- 4 Press the **DOWN** button to highlight System Options. Press the **SELECT** button.
- 5 Press the **DOWN** button to highlight Alarm Volume.
- 6 Press the **INC** or **DEC** buttons to change the setting.
- 7 Press the **BACK** button to return to the Edit Configuration screen, or press the **HOME** button to exit.
The new settings are saved.

16.7.2 Alarm Pulse

The alarm pattern can be changed. This is useful if several refrigerators with alarms are collocated, and distinguishing the source of the alarm quickly is desirable.

- ▶ Default setting is Single.
- ▶ Setting can be changed between Single, Double, Triple, and Constant.

Change the alarm pulse:

- 1 Press the **MAIN** button.
- 2 Press the **DOWN** button to highlight Edit Configuration. Press the **SELECT** button.
- 3 Enter the password when prompted.
- 4 Press the **DOWN** button to highlight System Options. Press the **SELECT** button.
- 5 Press the **DOWN** button to highlight Alarm Pulse.
- 6 Press the **INC** or **DEC** buttons to change the setting.
- 7 Press the **BACK** button to return to the Edit Configuration screen, or press the **HOME** button to exit.
The new settings are saved.

16.7.3 High Chamber Temperature Alarm

The High Alarm setpoint specifies the temperature at which the High Temperature Alarm activates. If the temperature detected by the chamber probe is greater than or equal to this value, the alarm activates.

- ▶ Default setpoint is 5.5 °C
- ▶ Setpoint can be changed from -40 °C to +40 °C

Change the setpoint:

- 1 Press the **MAIN** button.
- 2 Press the **DOWN** button to highlight Edit Configuration. Press the **SELECT** button.
- 3 Enter the password when prompted.
- 4 Press the **DOWN** button to highlight Alarm Setpoints. Press the **SELECT** button.
- 5 Press the **DOWN** button to highlight High Alarm Setpoint.
- 6 Press the **INC** or **DEC** buttons to change the setting.

- 7 Press the **BACK** button to return to the Edit Configuration screen, or press the **HOME** button to exit. The new settings are saved.

16.7.4 Low Chamber Temperature Alarm

The Low Alarm setpoint specifies the temperature at which the Low Temperature Alarm activates. If the temperature detected by the chamber probe is less than or equal to this value, the alarm activates.

- ▶ Default setpoint is 1.5 °C
- ▶ Setpoint can be changed from -40 °C to +40 °C

Change the setpoint:

- 1 Press the **MAIN** button.
- 2 Press the **DOWN** button to highlight Edit Configuration. Press the **SELECT** button.
- 3 Enter the password when prompted.
- 4 Press the **DOWN** button to highlight Alarm Setpoints. Press the **SELECT** button.
- 5 Press the **DOWN** button to highlight Low Alarm Setpoint.
- 6 Press the **INC** or **DEC** buttons to change the setting.
- 7 Press the **BACK** button to return to the Edit Configuration screen, or press the **HOME** button to exit. The new settings are saved.

16.7.5 Door Ajar Alarm

The Door Ajar Timeout specifies longest time the refrigerator door can be open before the alarm activates. If the time elapsed since the last door opening is greater than or equal to this value, the alarm activates.

- ▶ Default delay setting is three minutes
- ▶ Setting can be changed from 0 minutes to 60 minutes

Change the alarm delay:

- 1 Press the **MAIN** button.
- 2 Press the **DOWN** button to highlight Edit Configuration. Press the **SELECT** button.
- 3 Enter the password when prompted.
- 4 Press the **DOWN** button to highlight Alarm Setpoints. Press the **SELECT** button.
- 5 Press the **DOWN** button to highlight Door Ajar Timeout.
- 6 Press the **INC** or **DEC** buttons to change the setting.
- 7 Press the **BACK** button to return to the Edit Configuration screen, or press the **HOME** button to exit. The new settings are saved.

16.7.6 Power Failure Alarm

The Power Failure Timeout specifies longest time the refrigerator can be without AC power before the alarm activates. If the time elapsed since the last power failure is greater than or equal to this value, the alarm activates.

- ▶ Default delay setting is three minutes
- ▶ Setting can be changed from 0 minutes to 60 minutes

Change the alarm delay:

- 1 Press the **MAIN** button.
- 2 Press the **DOWN** button to highlight Edit Configuration. Press the **SELECT** button.
- 3 Enter the password when prompted.
- 4 Press the **DOWN** button to highlight Alarm Setpoints. Press the **SELECT** button.
- 5 Press the **DOWN** button to highlight Power Failure Timeout.
- 6 Press the **INC** or **DEC** buttons to change the setting.

- 7 Press the **BACK** button to return to the Edit Configuration screen, or press the **HOME** button to exit. The new settings are saved.

16.7.7

Chart Paper Alarm

The default setting for the chart paper timer is Enabled. One sheet of chart paper records temperatures continuously for seven days. The timer activates an alarm 6.5 days from when the timer is reset. The timer period cannot be changed.

NOTE

- ▶ Available options are Enabled, Disabled, and Reset.
 - ▶ Enabling the timer also resets the timer.
-

Change the setting:

- 1 Press the **MAIN** button.
- 2 Press the **DOWN** button to highlight Edit Configuration. Press the **SELECT** button.
- 3 Enter the password when prompted.
- 4 Press the **DOWN** button to highlight System Options. Press the **SELECT** button.
- 5 Press the **DOWN** button to highlight Chart Paper Timer.
- 6 Press the **INC** or **DEC** buttons to select Enabled, Disabled, or Reset.
- 7 Do one of the following:
 - ▶ If Enabled or Disabled is selected, press the **BACK** button to return to the System Options screen, or press the **HOME** button to exit. The new setting is saved.
 - ▶ If Reset is selected:
 - a Press the **DOWN** button.
 - b Press the **PAPER-CHANGED** button. The System Options screen appears with the Chart Paper Timer set to Enabled.
- 8 Press the **BACK** button to return to the System Options screen, or press the **HOME** button to exit. The new setting is saved.

16.8 Test Alarms

Test alarms to ensure they are working correctly. The refrigerator has alarms for chamber temperature, compressor temperature, door open (time), no battery, and power failure.



NOTICE Before testing alarms, protect items in the refrigerator from extended exposure to adverse temperature.

16.8.1 Manual Chamber Alarm Test

NOTICE Before testing alarms, protect items in refrigerator from extended exposure to adverse temperature.

IMPORTANT Perform the low alarm test before the high alarm test to control the temperature more closely and complete the testing more quickly.

Obtain:

- ▶ (2) 8 oz. (250 mL) glass half-full of chilled water
- ▶ (1) glass filled with crushed ice
- ▶ (1) 8 oz. (250 mL) glass half-full of warm water



NOTICE Temperature probes are fragile; handle with care.

Test the low alarm:

- 1 Identify setting for low alarm setpoint.
- 2 Remove chamber temperature probe from bottle.
- 3 Immerse probe in chilled water.
- 4 While stirring probe in chilled water, add approximately one teaspoon (5 mL) of ice every 20 seconds. Ensure probe is at the bottom of the glass.
- 5 When low temperature alarm activates, note the temperature on the Horizon Series display.

Test the high alarm:

- 1 Identify setting for high alarm setpoint.
- 2 While stirring probe in chilled water, add warm water so temperature increases 0.5 °C per minute.
- 3 When high temperature alarm activates, note the temperature on the Horizon Series display.
- 4 Remove probe from warm water.
- 5 Place temperature probe in probe bottle, immersing it at least 2" (50 mm).

16.8.2 Power Failure Alarm Test

- NOTE**
- ▶ During a power failure, the power failure alarm activates and the batteries provide power to the monitoring system.
 - ▶ If AC power fails, the backup batteries will allow for continued temperature display.
 - ▶ If the backup batteries fail, the temperature is not displayed.
 - ▶ When power is restored, the monitoring system resumes data display.
-

- 1 Confirm the refrigerator is connected to AC power.
- 2 Ensure the monitoring system backup batteries are installed.
- 3 Change Power Failure Timeout setting to 0 minutes.
 - a Press the **MAIN** button.
 - b Press the **DOWN** button to highlight Edit Configuration. Press the **SELECT** button.
 - c Enter the password when prompted.
 - d Press the **DOWN** button to highlight Alarm Setpoints. Press the **SELECT** button.
 - e Press the **DOWN** button to highlight Power Failure Timeout.
 - f Press the **DEC** button to change the setting to 0.
- 4 Disconnect the refrigerator from AC power. Power failure alarm will activate immediately.
- 5 Reconnect the refrigerator to AC power. Power failure alarm will clear and audible alarm will cease.
- 6 Change the Power Failure Timeout setting to the original setting.

16.8.3 Door Ajar Alarm Test

- 1 Change Door Ajar Timeout setting to 0 minutes:
 - a Press the **MAIN** button.
 - b Press the **DOWN** button to highlight Edit Configuration. Press the **SELECT** button.
 - c Enter the password when prompted.
 - d Press the **DOWN** button to highlight Alarm Setpoints. Press the **SELECT** button.
 - e Press the **DOWN** button to highlight Door Ajar Timeout.
 - f Press the **DEC** button to change the setting to 0.
 - g Press the **BACK** button to return to the Edit Configuration screen, or press the **HOME** button to exit. New settings are saved.
- 2 Open the door. Door ajar alarm will activate immediately.
- 3 Close the door. Door ajar alarm will clear and audible alarm will cease.
- 4 Change the Door Ajar Timeout setting to the original setting.

16.9 Additional System Settings

16.9.1 Screen Contrast

The screen contrast can be changed for easier viewing.

-
- NOTE**
- ▶ During an AC power failure, the screen backlight is not illuminated to conserve backup battery power.
 - ▶ During an AC power failure, the screen contrast cannot be changed.
-

Change screen contrast:

- 1 On the HOME screen, press the third button from the left to make the text appear lighter.
- 2 On the HOME screen, press the second button from the left to make the text appear darker.

16.9.2 Date and Time

The Date Format setting controls the order in which the month (mm) and day (dd) are displayed.

- ▶ Month is a 2-digit number (01-12)
- ▶ Day is a 2-digit number (01-31)
- ▶ Default date format is mm/dd/yyyy

The Clock Mode setting controls whether the time is displayed in a 12-hour or 24-hour format.

- ▶ When using the 12-hour format, AM or PM must be specified
- ▶ Default setting is 12-hour

Change date and time settings:

- 1 Press the **MAIN** button.
- 2 Press the **DOWN** button to highlight Edit Configuration. Press the **SELECT** button.
- 3 Enter the password when prompted.
- 4 Press the **DOWN** button to highlight Set Date & Time. Press the **SELECT** button.
- 5 Press the **UP** or **DOWN** buttons to select the date and time settings to change.
- 6 Press the **INC** or **DEC** buttons to change the setting.
- 7 Press the **BACK** button to return to the Edit Configuration screen, or press the **HOME** button to exit. The new settings are saved.

16.9.3 Display Language

The Horizon Series monitoring system stores two languages. English is the default language. If a different language is desired, it must be loaded from the flash memory card. If a flash memory card is not included with the refrigerator, the languages may have been loaded to the Horizon Series monitoring system prior to shipment.

To obtain a flash memory card to load an alternate language, contact Helmer Technical Service.

-
- NOTE** Each time the refrigerator is powered on, the Horizon Series monitoring system display language must be selected.
-

Set the display language on power-on:

- 1 Connect the refrigerator to AC power.
- 2 Install the monitoring system battery that is included in the accessory package.
 - ▶ The refrigerator powers on and the Horizon Series monitoring system will display the System Options screen.
- 3 Press the **INC** or **DEC** buttons to select the desired language. Press the **SELECT** button.

- 4 Press the **HOME** button to return to the HOME screen.
- 5 If a temperature alarm sounds, press the **MUTE** button.

Change the display language:

- 1 Press the **MAIN** button.
- 2 Press the **DOWN** button to highlight Edit Configuration. Press the **SELECT** button.
- 3 Enter the password when prompted.
- 4 Press the **DOWN** button to highlight System Options. Press the **SELECT** button.
- 5 Press the **UP** or **DOWN** buttons to select Language. Press the **SELECT** button.
- 6 Press the **INC** or **DEC** buttons to select the desired language.
- 7 Press the **BACK** button to return to the System Options screen, or press the **HOME** button to exit.
The new settings are saved.

16.9.4 Temperature Units

Available options are Celsius (°C) or Fahrenheit (°F). The default temperature unit is Celsius.

Change temperature units:

- 1 Press the **MAIN** button.
- 2 Press the **DOWN** button to highlight Edit Configuration. Press the **SELECT** button.
- 3 Enter the password when prompted.
- 4 Press the **DOWN** button to highlight System Options. Press the **SELECT** button.
- 5 Press the **DOWN** button to highlight Temperature Units.
- 6 Press the **INC** or **DEC** buttons to select the desired temperature units.
- 7 Press the **BACK** button to return to the Edit Configuration screen, or press the **HOME** button to exit.
The new setting is saved.

16.10 Upgrade System Firmware

Helmer may occasionally issue updates for the Horizon Series monitoring system firmware. Follow upgrade instructions included with the firmware update.

16.11 Reset the Horizon Series Monitoring System

- 1 Remove 1 battery from the monitoring system backup battery holder.
- 2 Disconnect the refrigerator from AC power.
- 3 Reconnect the refrigerator to AC power.
- 4 Reinstall the battery in the monitoring system backup battery holder.

16.12 View Manufacturer and Product Information

- 1 Press the **MAIN** button.
- 2 Press the **INC** or **DEC** buttons to select the Product/Company Information option. Press the **SELECT** button.
 - ▶ Manufacturer contact information appears.
 - ▶ Software version appears.

Temperature Controller Setpoints



Temperature controller display and buttons.

The temperature controller is located in the electrical box on the rear of the refrigerator. Temperature controller setpoints are programmed at the factory. Setpoints can be viewed and changed through the temperature controller. Parameter values reside in four program levels.

View or change parameter values:



NOTICE

Changing parameter values affects refrigerator operation. Do not change parameter values unless instructed by Helmer Technical Service.

NOTE

- ▶ To change the value for a parameter, first enter the program mode for that level.
- ▶ When there is no interaction for 60 seconds, the temperature controller exits program mode.

- 1 Enter Level 1 program mode:
 - a Press and hold the **UP** and **DOWN** buttons simultaneously for approximately three seconds.
 - b “tunE” and “oFF” flash on the display.
 - c The temperature controller is now in Level 1 program mode.
- 2 Select the parameter to be changed:
 - a Press and release the **UP** or **DOWN** buttons until the desired parameter flashes on the display.
 - b To access Level 2 or Level 3 parameters, select the “LEVL” parameter.
- 3 Change a parameter value:
 - a Press and hold the * button.
 - b Press the **UP** or **DOWN** buttons to change the parameter value.
 - c To access Level 2 parameters, change the value for the “LEVL” parameter to 2.
 - d To access Level 3 parameters, change the value for the “LEVL” parameter to 3.
- 4 Release all buttons to exit the parameter. New settings are saved.
 - ▶ If the “LEVL” parameter value is changed, the temperature controller returns to the selected program level.
- 5 Repeat steps 2 through 4 to access another program level, or to view or change parameter values in the selected level.
- 6 Access Level 4 parameters:
 - a Navigate to Level 3 program mode.
 - b Select the “UEr” parameter.
 - c Press and hold the **UP** and **DOWN** buttons simultaneously for approximately 10 seconds.
 - d The “LOCK” parameter flashes on the display.
- 7 Exit program mode:
 - a Press and hold the **UP** and **DOWN** arrow buttons simultaneously for approximately three seconds, or
 - b the current chamber temperature is displayed.

17.1 Level 1 Parameters and Values

- NOTE**
- ▶ Parameters are listed in order of appearance.
 - ▶ The temperature controller is programmed at the factory with a refrigerator setpoint of 4.0 °C.

Parameter	Description	Default Value
<i>tunE</i>	Autotune selection	oFF
<i>bAnd</i>	SP1 proportional band (gain) or hysteresis (in °C)	4.0
<i>int.t</i>	SP1 integral time/reset (in minutes)	oFF
<i>dEr.t</i>	SP1 derivative time/rate	oFF
<i>dAC</i>	SP1 derivative approach control	0.5
<i>CYC.t</i>	SP1 mode selection (ON/OFF or proportional cycle-time)	on.oF
<i>oFSt</i>	SP1 offset (manual reset)	0.0
<i>SPLt</i>	Lock main setpoint	oFF
<i>SPrr</i>	Ramp rate (if ramp is on)	0
<i>SPrn</i>	Ramp selection	oFF
<i>SoAt</i>	Soak time selection	--
<i>ALLo</i>	SP2 low alarm setpoint (in °C)	0.0
<i>ALHi</i>	SP2 high alarm setpoint (in °C)	0.0
<i>bnd.2</i>	SP2 hysteresis or proportional band (in °C)	0.1
<i>CYC.2</i>	SP2 mode selection (ON/OFF or proportional cycle-time)	on.oF
<i>LEUL</i>	Parameter level currently selected	1

17.2 Level 2 Parameters and Values

Parameter	Description	Default Value
<i>SP IP</i>	Display of SP1 output power percentage (read-only)	(read only)
<i>hAnd</i>	Selection for manual control of power for SP1	oFF
<i>PL.1</i>	SP1 power limit percentage	100
<i>PL.2</i>	SP2 power limit percentage (cooling)	0
<i>SP2.A</i>	Main SP2 operating mode (alarm strategy)	nonE
<i>SP2.b</i>	Subsidiary SP2 mode	nonE
<i>d, SP</i>	Display resolution	0.1°
<i>hi.SC</i>	Full scale	20.0
<i>LoSC</i>	Minimum scale	0.0
<i>, nPt</i>	Input sensor type	rtd
<i>uni t</i>	Units (°C/ °F)	°C
<i>LEUL</i>	Parameter level currently selected	2

17.3 Level 3 Parameters and Values

Parameter	Description	Default Value
<i>SP Id</i>	SP1 output device type	SSd1
<i>SP2.d</i>	SP2 output device type (read only)	SSd2
<i>burn</i>	Sensor burn-out protection type (upscale or downscale)	uP.SC
<i>rEUD</i>	Output mode (reverse or direct)	1d.2d
<i>rEUL</i>	LED indicator modes for SP1 and SP2 (normal or inverted)	1i.2n
<i>SPAN</i>	Sensor span adjust	0.0
<i>ZEro</i>	Zero sensor error (calibration across full scale)	0.0
<i>ChEE</i>	Selection for the control accuracy monitor	oFF
<i>rEAd</i>	Read control accuracy monitor results (variance)	UAr°
<i>tECh</i>	Read autotune tuning cycle data	Ct A
<i>UEr</i>	Software version (Select this parameter to access Level 4 parameters)	392b
<i>rSEt</i>	Functions reset	nonE
<i>LEUL</i>	Parameter level currently selected	3

17.4 Level 4 Parameters and Values

Parameter	Description	Default Value
LoCK	Program security lock	nonE
dEr.S	Derivative sensitivity	0.5
di.S.S	Display sensitivity (or direct display of input)	dir
noAL	Disable SP2 alarm annunciator	oFF
ProG	Program mode auto-exit switch (returns display to normal mode if no activity for one minute)	Auto

17.5 Change the Refrigerator Setpoint



Independent temperature controller.



NOTICE

- ▶ Do not change the setpoint to a value outside the temperature control range.
- ▶ Parameter values are factory-preset and should not be changed unless directed by Helmer Technical Service.

NOTE

- ▶ Default setpoint varies for each refrigerator.
- ▶ Setpoint is adjusted to achieve an average chamber temperature of 4.0 °C.
- ▶ The reference temperature displayed on the temperature controller may not be the same as the temperature displayed on the Horizon Series monitor.
- ▶ Allow the temperature to stabilize for 10 minutes prior to changing the setpoint again.

- 1 Observe the average chamber temperature displayed on the Horizon Series monitoring system, after the monitoring system probe has been calibrated.
- 2 Determine how much the refrigerator setpoint will be changed.

EXAMPLE

- ▶ Average observed temperature is 3.5 °C
- ▶ Desired average temperature is 4.0 °C
- ▶ Current setpoint is 6.0 °C
- ▶ Adjust setpoint to 6.3 °C

- 3 Access the setpoint adjustment function:
 - a Press and hold the * button.
 - ▶ The controller displays current setpoint value.
- 4 Change the setpoint by the setpoint adjustment value:
 - a Press and hold the * button.
 - b Press the **UP** or **DOWN** buttons to increase or decrease setpoint in increments of 0.1 °C.
- 5 Release all buttons to exit the setpoint parameter. New settings are saved.

17.6

Change the Hysteresis Value

- ▶ Default setpoint for is 4.0 °C
- ▶ Allowable temperature variance on each side of the refrigerator setpoint



NOTICE Hysteresis is factory-preset and should not be changed unless directed by Helmer Technical Service.

18

Maintenance



NOTICE

- ▶ Before performing maintenance, protect items in refrigerator from extended exposure to adverse temperature.
- ▶ Allow refrigerator temperature to stabilize at setpoint after performing service or after extended door opening.

NOTE Refer to the operation manual for the preventive maintenance schedule.

18.1

Recharge Refrigerant



CAUTION

- ▶ Review all safety instructions prior to recharging refrigerant. Refer to chapter 2 (Safety).
- ▶ Maintenance should only be performed by trained refrigeration technicians.



NOTICE Use only non-CFC R-134A refrigerant.

Full initial refrigerant charge varies by model and power requirements, which can be found on the product specification label.

Model	Voltage	Initial Charge
111	Any	7.5 oz. (213 g)
120/125	Any	10.0 oz. (283 g)
245/256	115 V, 60 Hz	Contact Helmer Technical Service
	230 V, 50/60 Hz	20.0 oz. (567 g)

Obtain:

- ▶ Refrigerant
- ▶ Calibrated pressure gauge (0 psi to 25 psi (0 kPa to 175 kPa))

Add refrigerant:

- 1 Attach pressure gauge to the fittings on the refrigeration lines.
- 2 Monitor the low side (suction) pressure through a full compressor cycle.
- 3 Measure the pressure at the end of the next cycle, immediately before the compressor stops.

NOTE Pressure varies depending on ambient air temperature.

- 4 Add refrigerant. Check the pressure on the low side.
 - ▶ Low side = 16 psi to 18 psi (110 kPa to 125 kPa)
- 5 Remove pressure gauge.

18.2 Test Monitoring System Backup Batteries

The Horizon Series monitoring system does not have visual indicators for battery charge level. If the batteries deplete to a particular voltage output, the batteries will not provide power to the monitoring system.

Test backup batteries:

- 1 Disconnect the refrigerator from AC power.
 - ▶ Screen should continue to display information without backlight.
 - ▶ If the display is blank, replace batteries.
- 2 Reconnect the refrigerator to AC power.

18.3 Replace Monitoring System Backup Batteries

On the top of the freezer, remove six batteries and replace with six new batteries.



NOTICE When installing replacement batteries, use only batteries which meets the specifications outlined in chapter **18.7** (Supplies).

18.4 Replace the Fluorescent Lamps

- 1 Disconnect the refrigerator from AC power. Remove one battery from the monitoring system backup battery holder.
- 2 Single-door refrigerators: Remove drawers, shelves, baskets, and slides on the right side of the chamber.
- 3 Press short side of diffuser and unsnap it to remove from the light base.
- 4 Rotate defective light bulb and remove from the sockets.
- 5 Insert new light bulb into the sockets and rotate to lock into place.
- 6 Snap diffuser into the light base.
- 7 Reinstall the battery in the monitoring system backup battery holder. Reconnect the refrigerator to AC power.
- 8 Single-door refrigerators: Replace drawers, shelves, baskets, and slides.
- 9 Press the **MUTE** button to disable the high temperature alarm while refrigerator reaches operating temperature.

18.5 Clean the Refrigerator

18.5.1 Condenser Grill

In environments where refrigerator is exposed to excessive lint or dust, condenser grill may require cleaning more frequently than stated in preventive maintenance schedule.

Clean the condenser grill using a soft brush and a vacuum cleaner.

18.5.2 Exterior

Clean exterior surfaces with soft cotton cloth and non-abrasive liquid cleaner.

18.5.3 Interior

Clean painted surfaces with mild detergent. Clean stainless steel surfaces with a general-purpose laboratory cleaner suitable for stainless steel.

18.5.4 Door Gaskets

Clean with soft cloth and mild soap and water solution.

18.5.5 Clean and Refill Probe Bottle

NOTE A kit that includes a probe bottle and glycerin is available from Helmer.

Obtain:

- ▶ Fresh water-bleach solution (not provided)
 - ▶ 1:9 ratio of bleach to water
 - ▶ Bleach is 5% solution of commercial sodium hypochlorite (NaOCl)
 - ▶ Equivalent oxidizing cleaner/disinfectant approved by your organization may be substituted
- ▶ 4 oz. (120 mL) of product simulation solution per bottle
 - ▶ 10:1 ratio of water to glycerin

Clean and refill bottle:

- 1 Remove probe from bottle.
- 2 Remove bottle from bracket.
- 3 Clean bottle with water-bleach solution.
- 4 Fill bottle with 4 oz. (120 mL) of product simulation solution.
- 5 Cap bottle tightly to minimize evaporation.
- 6 Place bottle in bracket.
- 7 Replace probe, immersing at least 2" (50 mm).

18.6 Unit Cooler Cover Removal and Installation

If unit cooler cover is not removed as detailed in this procedure the drain port may be damaged. Improper drainage may result in excessive icing and refrigerator's inability to maintain temperature.

Required tools:

- ▶ 5/16" socket wrench
- ▶ Tool to push putty away from the drain hose

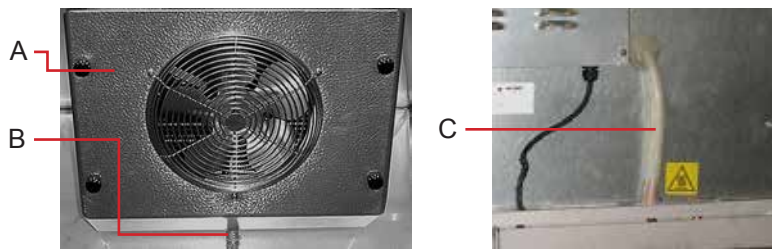

Drain line and hose.

Label	Description
A	Unit cooler cover
B	Drain port
C	Drain hose

18.6.1 Remove the Unit Cooler Cover



WARNING Disconnect the refrigerator from AC power when removing the unit cooler.



CAUTION The condensate evaporator and water evaporation tray are hot.

- 1 Disconnect the refrigerator from AC power. Remove one battery from the monitoring system backup battery holder.
- 2 Remove top drawer, basket, or shelf from the chamber.
- 3 On the back of the chamber, peel putty back to expose drain hose (C).
- 4 Remove drain hose from unit cooler drain port (B).
 - a Pull drain hose downward to separate from unit cooler.
 - b Twist drain hose while pulling to assist in removal.
- 5 Push the drain hose (C) out through rear of chamber.
- 6 Remove the unit cooler cover.
 - a Hold unit cooler cover in place to prevent it from dropping.
 - b Use the socket wrench to remove four screws securing the unit cooler cover.
 - c Carefully lower unit cooler cover to avoid damage to the fan wiring.

18.6.2 Install the Unit Cooler Cover

- 1 Verify unit cooler wiring is connected and routed correctly.
 - a Wiring should be routed above copper tube inside the unit cooler.
 - b Reconnect wires if they have separated.
- 2 Attach unit cooler cover.
 - a Lift unit cooler cover into place.
 - b Front edge of the cover should be behind the unit cooler case.
 - c Use the socket wrench to install four screws to secure the unit cooler cover.
- 3 Insert the drain hose through hole in the refrigerator.
 - a Push drain hose upward, toward the unit cooler drain port.
 - b In the chamber, push drain hose onto unit cooler drain port.
- 4 On the back of the chamber, press putty around the drain hose.
- 5 Reinstall the top drawer, shelf, or basket.
- 6 Reinstall the battery in the monitoring system backup battery holder. Reconnect the refrigerator to AC power.
- 7 Press the **Mute** button to disable the high temperature alarm while refrigerator reaches operating temperature.

18.7 Supplies

Refrigerant: non-CFC, R-134A

Chart paper: 220366 (52 sheets)

Glycerin solution: 400922-1

Fluorescent lamp: T5, 13 W

Monitoring system batteries: (6) 1.5 V, D-cell non-rechargeable alkaline batteries (or equivalent): 715031

Chart recorder battery (optional): (1) 9 V non-rechargeable alkaline (or equivalent): 120218

19 Troubleshooting



- CAUTION**
- ▶ Review all safety instructions prior to troubleshooting. Refer to chapter 2 (Safety).
 - ▶ Troubleshooting should only be performed by trained refrigeration technicians.

19.1 General Operation Problems

Problem	Possible Cause	Action
Drawer or basket does not slide easily.	Drawer slide is faulty.	▶ Confirm the slide is operating correctly. Replace if necessary.
	Debris in the drawer slides.	▶ Pull the drawer or basket out and confirm the slides are free of debris. Clean if necessary.
	Drawer slides are not lubricated.	▶ Using a lightweight oil, lubricate the bearings in the slides.
	Drawer or basket is misaligned or not level.	▶ Confirm both slides for the drawer or basket are mounted at the same height.
Door does not open easily.	Debris in the hinges.	▶ Confirm the hinges are free of debris. Clean the hinges if necessary.
	Door hinges are not lubricated.	▶ Using a general-purpose grease, lubricate the pivots in the hinges.
	Hinge cam is faulty.	▶ Confirm the hinge cam is not damaged. Replace if necessary.
Monitor display is hard to read.	Screen contrast is set too low.	▶ Change the screen contrast.
Alarm monitor is not responding.	Digital electronics are locked because of an interruption in power.	▶ Reset the monitoring system.
Chamber temperature meets an alarm condition, but the appropriate temperature alarm is not active.	Temperature alarm setpoint was changed.	▶ Check the current setpoints for the temperature alarms. Change the setpoints if necessary.

19.2 Chamber Temperature Problems

Problem	Possible Cause	Action
Chamber temperature displayed is higher or lower than the actual temperature.	Chamber temperature probe connection is loose.	▶ Test the probe connection. Secure the connection if necessary.
	Temperature probe wiring is an open circuit.	▶ Check the continuity of the probe wiring. Replace the probe if necessary.
	Probe bottle is empty, or solution is too low.	▶ Check the level of product simulation solution in the bottle. Refill the bottles if necessary.
	Monitor is not calibrated.	▶ Confirm the temperature probe is reading correctly. Calibrate the probe if necessary.
	Digital electronics are locked because of an interruption in power.	▶ Reset the monitoring system.
	A component is faulty or internal connections are loose.	▶ Contact Helmer Technical Service.
Chamber temperature does not stabilize at the refrigerator setpoint.	Compressor starting relay is faulty.	▶ Confirm the relay is operating correctly. Replace the relay if necessary.
	Temperature controller is faulty.	▶ Confirm the temperature controller is operating correctly. Replace it if necessary.
	Condensing unit fan is not running.	▶ Check the condensing unit fan connections. Replace the fan motor if necessary.
	Unit cooler fan is not running.	▶ Check the voltage to the fan when door switch is activated. Replace the fan motor or door switch if necessary.
	Compressor motor has seized.	▶ Replace the compressor.
	Temperature control probe is faulty.	▶ Confirm the probe is providing resistance in the range of 98 Ω to 110 Ω. Replace the probe if necessary.
	Refrigerant level is too low.	▶ Check the refrigeration lines for leaks and repair them if necessary.
		▶ Check the refrigerant level. Recharge the refrigerant if necessary.
	Condenser grill is dirty.	▶ Check the condenser grill. Clean it if necessary.
	Circulation at the top of the chamber is not adequate.	▶ Check if there are any items that may obstruct air flow and remove them if necessary.
	Ambient air temperature is too high.	▶ Confirm the refrigerator is placed appropriately. Refer to the operation manual.
	A component is faulty or internal connections are loose.	▶ Contact Helmer Technical Service.
Probe bottle is empty, or solution is too low.	▶ Check the level of product simulation solution in the bottle. Refill the bottles if necessary.	

Problem	Possible Cause	Action
Compressor runs continuously.	Refrigerator setpoint is set too low.	▶ Confirm the setpoint is set within the operating range. Change the setpoint if necessary.
	Temperature control probe is faulty.	▶ Confirm the probe is providing resistance in the range of 98 Ω to 110 Ω. Replace the probe if necessary.
	Temperature controller is faulty.	▶ Confirm the temperature controller is operating correctly. Replace the board if necessary.
	Compressor starting relay is faulty.	▶ Confirm the relay is operating correctly. Replace it if necessary.

19.3

Alarm Activation Problems

Problem	Possible Cause	Action
Refrigerator is in an alarm condition, but alarms are not audible.	Alarm system is faulty.	▶ Confirm the circuit board and line connections are functioning correctly.
	Control board is faulty.	▶ Replace control parts with those that are included in the control and display board kit.
	Alarm buzzer is faulty.	▶ Replace the alarm buzzer.
	Audible alarms have been muted.	▶ Verify audible alarms are not muted. If the time remaining on the MUTE timer is greater than 5 minutes, change the MUTE timer value to 5 minutes and wait until the timer resets.
	A component is faulty or internal connections are loose.	▶ Contact Helmer Technical Service.
Refrigerator meets an alarm condition, but the appropriate alarm is not active.	Control board is faulty.	▶ Replace control parts with those that are included in the control and display board kit.
	Alarm setpoint was changed.	▶ Check the current setpoints for the alarms. Change the setpoints if necessary.
	A component is faulty or internal connections are loose.	▶ Contact Helmer Technical Service.

Problem	Possible Cause	Action
High Temperature alarm activates when the door is opened, then clears shortly after the door is closed.	Chamber temperature probe connection is loose.	▶ Test the probe connections. Secure the connections if necessary.
	Chamber temperature probe is faulty.	▶ Test the probe. Replace the probe if necessary.
	Unit cooler fan continues to run while the door is open.	▶ Test the door switch and unit cooler fan connections. Secure the connections if necessary. Replace the door switch or fan motor if necessary.
	Probe bottle is empty.	▶ Check level of product simulation solution in the bottle. Refill bottles if needed.
	High temperature alarm setpoint is set too low.	▶ Check the setpoint. Change the setpoint if necessary.
	A component is faulty or internal connections are loose.	▶ Contact Helmer Technical Service.
Refrigerator is connected to power, but the AC Power Failure alarm is active.	Outlet connection is faulty.	▶ Verify power at the outlet. Repair the original outlet or connect to a different outlet if necessary.
	Power cord is faulty.	▶ Confirm the power cord is connected securely. Secure the power cord if necessary.
	Power supply board is faulty.	▶ Replace the power supply board.
	Circuit breaker was tripped (230 V models).	▶ Confirm the circuit breaker is seated. Push the circuit breaker to reset it if necessary.
	A component is faulty or internal connections are loose.	▶ Contact Helmer Technical Service.
Door Open alarm is activating sporadically.	Door(s) not closing completely.	▶ Confirm the hinge cams are not damaged. Replace the hinge cams if necessary.
	Door(s) closing but not sealing completely.	▶ Confirm the door gasket seals completely. Replace the door gasket if necessary.
	Door switch connection(s) is faulty.	▶ Test the switch connections. Secure the connections if necessary.
	One or both door switches are faulty.	▶ Replace the door switch(s).
	Control board is faulty.	▶ Replace control parts with those that are included in the control and display board kit.
	Door Ajar Timeout is set to zero, causing the alarm to activate immediately when the door is opened.	▶ Check the current setpoint for the Door Ajar alarm. Change the setpoint if necessary.

Problem	Possible Cause	Action
All alarms are activating sporadically.	Alarm system is faulty.	▶ Confirm the circuit board and line connections are functioning correctly.
	A component is faulty or internal connections are loose.	▶ Contact Helmer Technical Service.
	Control board is faulty.	▶ Replace control parts with those that are included in the control and display board kit.
An alarm activated, but the temperature recorded at activation does not match the alarm setpoint.	Monitor is not calibrated.	▶ Confirm the temperature probe is reading correctly. Calibrate the probe if necessary.
	Temperature changed slightly around the time of activation.	▶ No action needed.

19.4

Condensation Problems

Problem	Possible Cause	Action
Excessive water in the water evaporation tray.	Heater in the evaporation tray is faulty.	▶ Confirm the heater is hot and is drawing the appropriate current. ▶ For 115 V refrigerators, the current should be approximately 0.43 A to 0.55 A. ▶ For 230 V refrigerators, the current should be approximately 0.21 A to 0.35 A.
	Humid air is entering the chamber.	▶ Confirm the refrigerator is level, and the doors are aligned, closing tightly, and sealing correctly. ▶ Contact Helmer Technical Service to correct issues as necessary.
Excessive water in the chamber.	Humid air is entering the chamber.	▶ Confirm the refrigerator is level, and the doors are aligned, closing tightly, and sealing correctly. Correct issues as necessary.
	Connection between the unit cooler and the drain tube is loose.	▶ Confirm the connection is secure. Tighten the connection if necessary.
	Drain line is plugged.	▶ Confirm the drain tube is free of debris. Remove debris if necessary.
Excessive humidity on the doors.	Humid air is entering the chamber.	▶ Confirm the refrigerator is level, and the doors are aligned, closing tightly, and sealing correctly. Correct issues as necessary.
	Relative humidity around the refrigerator is too high.	▶ Confirm the refrigerator is placed properly. Refer to the operation manual.

20 Parts



NOTICE

- ▶ Before replacing parts, protect items in refrigerator from extended exposure to adverse temperature.
- ▶ Allow refrigerator temperature to stabilize at setpoint after replacing parts or after extended door opening.

20.1 Front

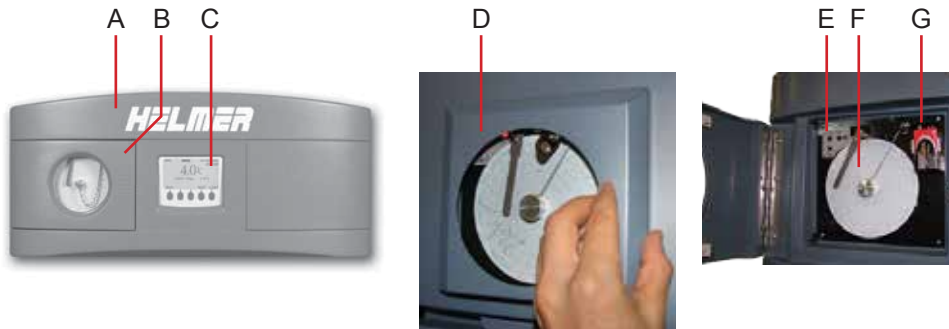

Front features.

Label	Description	Part Number	Schematic Label
A	Bezel with chart recorder door	Contact Helmer Technical Service	-
B	Chart recorder door	Contact Helmer Technical Service	-
C	Horizon Series display	Refer to subsequent section(s) for part numbers	K
D	Chart recorder and chart recorder door	111 model: 400409-2	X
E	Chart recorder and chart recorder door	120, 125, 245, and 256 models: 400409-2	X
F	Chart paper	220366 (package of 52 sheets)	-
G	Chart recorder backup battery (9 V alkaline, non-rechargeable)	120218	AD
Not shown	Caster (swivel with brake)	Serial number 974891 and earlier: 220380 Serial number 947892 and later: 220467	-

20.1.1 Horizon Display

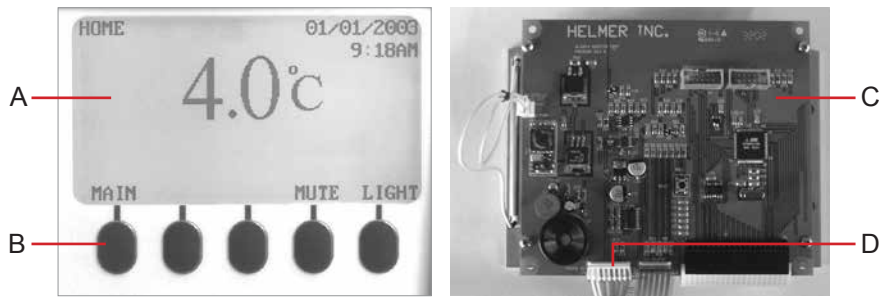

Left: Display assembly showing LCD and touchpad. Right: Display board.

Label	Description	Part Number	Schematic Label
A	LCD board	120452	K
B	Touchpad	320722-1	K
C	Display board	Included in the control and display board kit	K
D	Interface cable	400502-1	AF
Not shown	Display assembly	400509-1 (Includes LCD board and touchpad)	K



NOTICE The Horizon display assembly is sensitive to static electricity and can be damaged by electrostatic discharge. Use proper ESD precautions when handling the display assembly.

NOTE Although the LCD display and touchpad may be replaced individually, Helmer recommends replacing the entire display assembly.

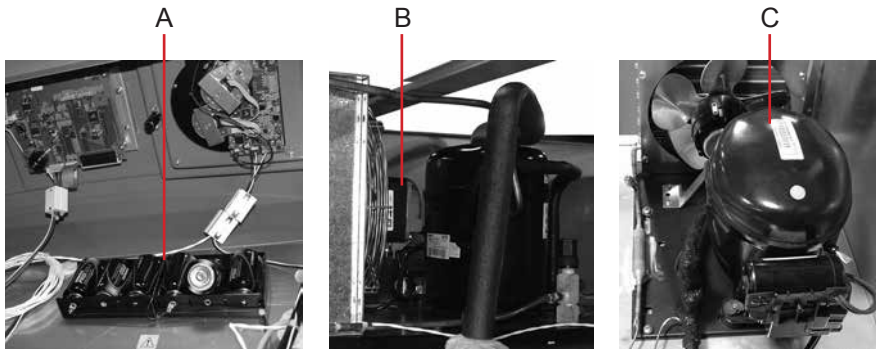

Top features.

Label	Description	Part Number	Schematic Label
A	Monitoring system backup batteries	715031	AE
B	Compressor unit	Contact Helmer Technical Service	A
C	Condensing unit fan motor	Contact Helmer Technical Service	U

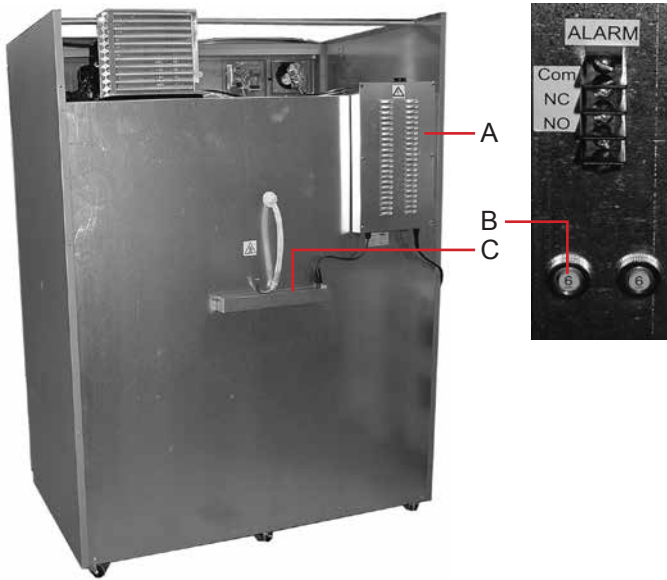

Rear features.

Label	Description	Part Number	Schematic Label
A	Electrical box	Refer to subsequent section(s) for part numbers	-
B	Circuit breaker, 6 A	Single-door 230 V models: 120429	P
	Circuit breaker, 7 A	Double-door 230 V models: 120428	P
C	Condensate evaporator kit (Includes the condensate evaporator and water evaporation tray)	115 V: 111 models: 400791-1 120, 125, 245, and 256 models: 400790-1 230 V: 111 models: 400791-2 120, 125, 245, and 256 models: 400790-2	J

20.3.1 Electrical Box

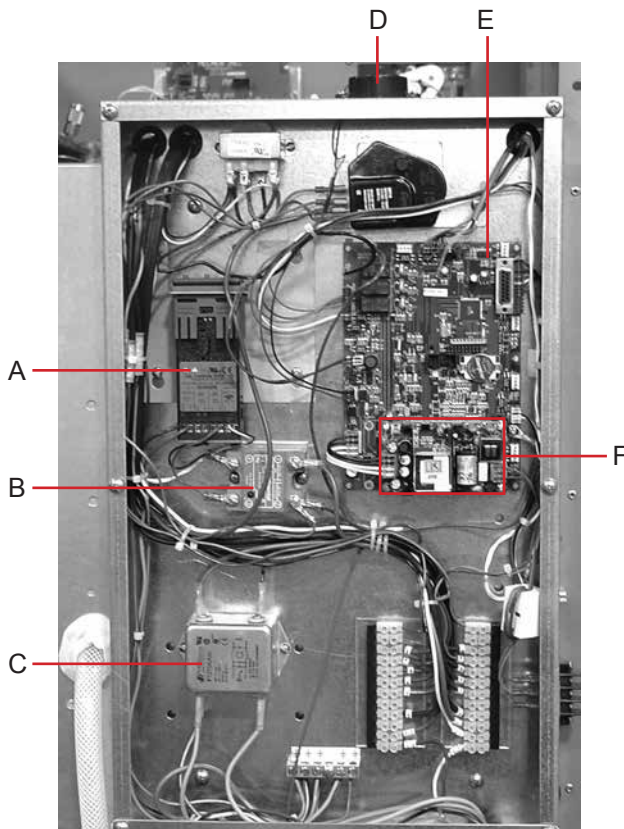

Electrical box features.

Label	Description	Part Number	Schematic Label
A	Temperature controller (programmed)	400422-1	B
B	Compressor relay	120426	AA
C	Power line filter	120400	AK
D	Alarm buzzer	120457	D
E	Control board	Included in the control and display board kit	E
F	Power supply board	400633-1	AH
Not shown	Control and display board kit	400651-2 (Includes the control board, display board, power supply board, and interface cable)	K,E



Interior features.

Label	Description	Part Number	Schematic Label
A	Chart recorder probe	400855-1	AI
B	Chamber probe	800117-1	AB
C	Probe bottle and glycerin kit	400922-1	-
D	Unit cooler	Refer to subsequent section(s) for part numbers	AG
E	Door switch	120380	I
F	Door	Refer to subsequent section(s) for part numbers	-
G	Storage parts	Refer to subsequent section(s) for part numbers	-
H	Lamp assemblies	Refer to subsequent section(s) for part numbers	M

20.4.1 Lighting

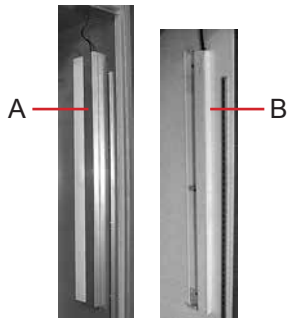

Light features.

Label	Description	Part Number	Schematic Label
A	Light assembly (models with stainless steel interior)	115 V: 400508-1 230 V: 400508-2	M
B	Light assembly (models with powder-coated interior)	115 V: 400507-2 230 V: 400507-1	M
Not shown	Light bulb	120409	-

20.4.2 Unit Cooler

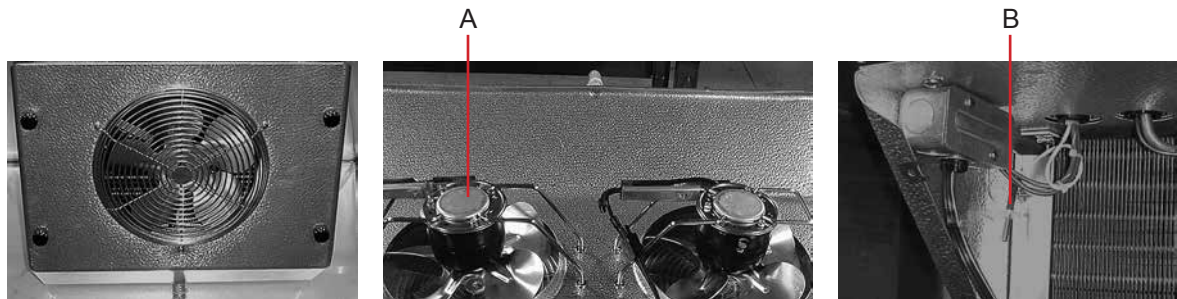

Left: Unit cooler (single-door model shown). Center and right: Unit cooler parts.

Label	Description	Part Number	Schematic Label
A	Unit cooler fan motor	115 V 111 models: 120540 120 and 125 models: 120411 245 and 256 models (one fan): 120587 245 and 256 models (two fans): 120410 230 V 111 models: 120560 120 and 125 models: 120415 245 and 256 models (one fan): 120588 245 and 256 models (two fans): 120545	H
B	Temperature control probe	400854-1	G

20.4.3 Storage



Storage features.

Label	Description	Part Number
A	Half shelf (includes hardware)	120, 125, 245, 256 models: 400413-1
B	Full shelf (includes hardware)	111 models: 400414-3 120 and 245 models: 400414-1 125 and 256 models: 400414-2
C	Roll out basket assembly (includes 2 slides, and hardware)	111 models: 400751-1 120 and 245 models: 400415-1 125 and 256 models: 400415-2
D	Drawer assembly (includes 2 slides and hardware)	111 models: 400752-2 120 and 245 models: 400370-3 125 and 256 models: 400370-4
Not shown	Slide assembly (includes 2 slides)	111 models: 400753-1 120 and 245 models: 400714-1 125 and 256 models: 400714-2

20.4.4 Door and Hinge



Door and hinge parts.

Label	Description	Part Number
A	Door lock	220374
B	Door handle pad	320684-1
C	Hinge bearing	220375
D	Upper hinge bracket	Right hinge: 400376-1 Left hinge: 400376-2
E	Door gasket	111 models: 321082-1 120, 125, 245, and 256 models: 320726-1
F	Hinge cam	320742-1
G	Door stop	320763-1
H	Lower hinge bracket	Right hinge: 400377-1 Left hinge: 400377-2

21 Schematics

21.1 HB Models; 11, 20, 25, 45, 56 Cubic Feet

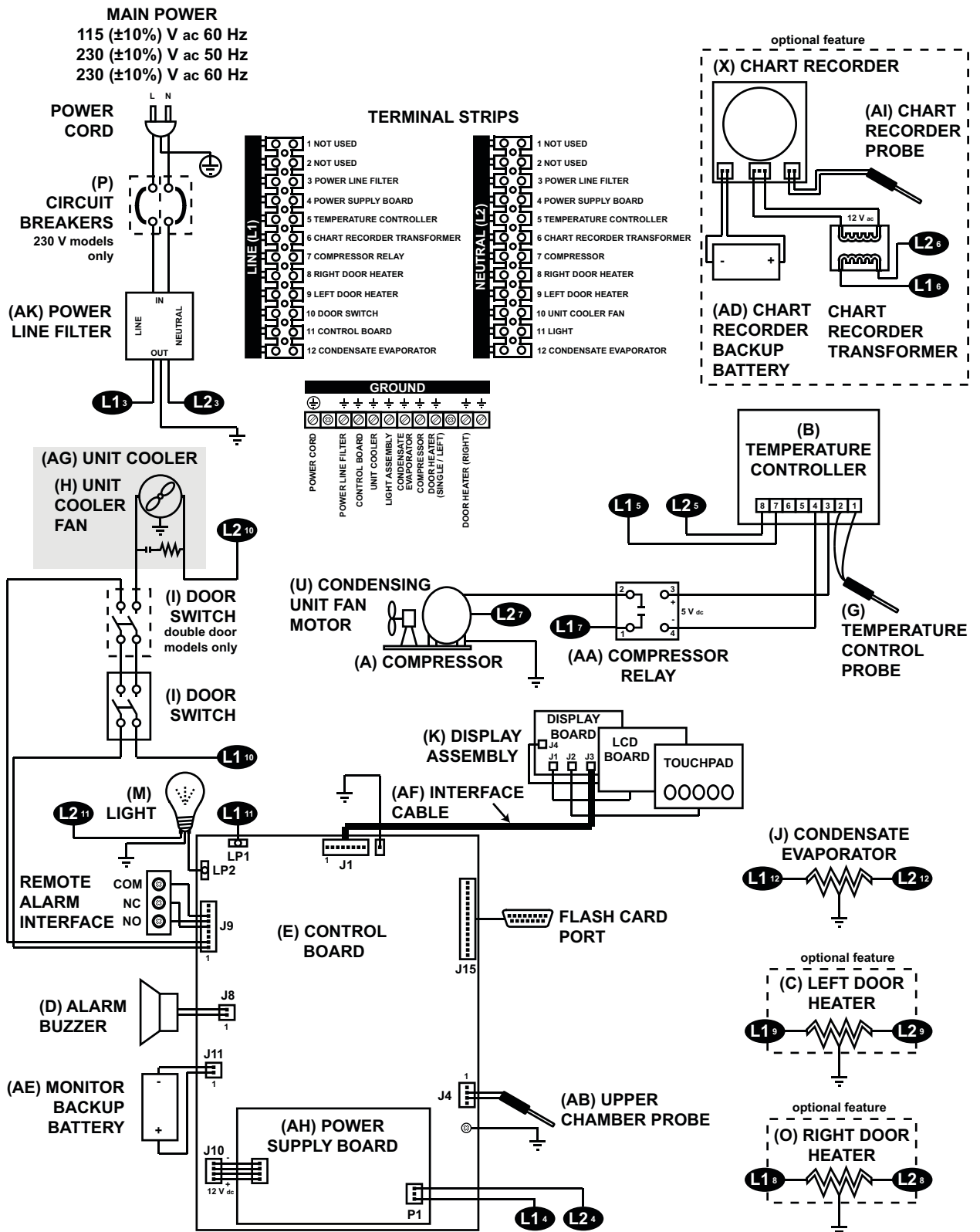

22 Horizon Series Screen Reference**HOME** screen**MAIN** button**MAIN** screen**MUTE** button (changes mute timer)**LIGHT** button (turns light on or off)**MAIN** screen**Edit Configuration** option

(Enter the password)

CONFIGURATION screen**View Configuration** option**VIEW CONFIGURATION** screen**Product/Company Information** option**INFORMATION** screen**CONFIGURATION** screen**Set Date & Time** option**SET DATE & TIME** screen**System Options** option**SYSTEM OPTIONS** screen**Alarm Setpoints** option**SET ALARM SETPOINT** screen**Temperature Calibration** option**TEMPERATURE CALIBRATION** screen**Factory Default Settings** option**FACTORY DEFAULT SETTINGS** screen**Change Password** option

(Enter a new password)

SYSTEM OPTIONS screen**Language** option**Date Format** option**Alarm Volume** option**Alarm Pulse** option**Temperature Units** option**Chart Paper Timer** option**SET ALARM SETPOINT** screen**High Alarm Setpoint** option**Low Alarm Setpoint** option**Door Ajar Timeout** option**Power Failure Timeout** option**TEMPERATURE CALIBRATION** screen**Upper Temperature Probe** display**Temperature** option

VIEW CONFIGURATION screen**Clock Mode** display**Date Format** display**Door Ajar Timeout** display**Pwr Failure Timeout** display**High Alarm Setpoint** display**Low Alarm Setpoint** display**Alarm Volume** display**Alarm Pulse** display**Chart Paper Days Left** or **Chart Paper Timer** display

Section IV: Horizon Series™ - Laboratory, Pharmacy, and International Blood Bank Models

NOTE This section applies to HHB, HLR, and HPR models.

23 Product Configuration

23.1 Install Battery for Backup Power

The monitoring system has a battery system, enabling a period of continuous operation if power is lost.

NOTE The monitoring system will start on battery power alone. If the refrigerator was previously not connected to AC power and the battery is connected, the monitoring system will begin running on battery power.

Battery life varies by manufacturer as well as voltage level remaining. Providing full power is available and no battery-related alarms are active, backup power for the monitoring system is available for up to two hours.



NOTICE When installing replacement batteries, use only batteries which meets the specifications outlined in chapter **25.7** (Supplies).

The battery is located on the top of the refrigerator, behind the monitoring system. For 111 models, a service cover covers the components and an access panel provides access to the monitoring system backup battery.



Monitoring system backup battery.

Monitoring system battery is included in the accessory package. Install and connect the battery to provide monitoring system with backup power in the event of an AC power failure.

23.2 External Monitoring Devices



- CAUTION**
- ▶ The interface on the remote alarm monitoring system is intended for connection to the end user's central alarm system(s) that uses normally-open or normally-closed dry contacts.
 - ▶ If an external power supply exceeding 30 V (RMS) or 60 V (DC) is connected to the remote alarm monitoring system's circuit, the remote alarm will not function properly; may be damaged; or may result in injury to the user.
-

NOTE In the event of a power failure, the power failure alarm condition is transmitted through the remote alarm contacts.

The remote alarm interface is a relay switch with three terminals:

- ▶ Common (COM)
- ▶ Normally Open (NO)
- ▶ Normally Closed (NC)

Terminals are dry contacts and do not supply voltage. Interface circuit is either normally open or normally closed, depending on terminals used. Requirements for your alarm system determine which alarm wires must connect to terminals.

- ▶ 0.25 A at 30 V (RMS); 0.25 A at 60 V (DC)

23.2.1 Connect to Remote Alarm Interface

- 1 Disconnect AC power from the refrigerator. Disconnect the monitoring system backup battery.
- 2 On the electrical box, locate the remote alarm terminals.
- 3 Connect remote alarm wires to appropriate terminals, according to requirements for your alarm system.
- 4 Use a cable tie to relieve strain on alarm wires (as necessary).
- 5 Reconnect the refrigerator to AC power. Reconnect the monitoring system backup battery.
- 6 Press the **MUTE** button to disable the high temperature alarm while refrigerator reaches operating temperature.



Storage features.



CAUTION

- ▶ Keep hands away from pinch points when closing the door.
- ▶ Before moving drawers, ensure they are completely empty for safe lifting.
- ▶ Maximum basket, drawer, or shelf load is 100 lbs (46 kg).



NOTICE

Before moving storage components, protect stored items in refrigerator from extended exposure to adverse temperature.

Remove a drawer or basket

- 1 Pull drawer or basket out until it stops.
- 2 On the right rail, locate the release tab and press downward.
- 3 While holding the right release tab downward, locate the release tab on the left rail and press upward.
- 4 Pull drawer or basket free of the slides.

Install a drawer or basket

- 1 Align end guides on drawer or basket with the slides.
- 2 Gently push drawer or basket into chamber until it stops.
- 3 Pull drawer or basket out until it stops; check for smooth operation.

Remove a shelf

- 1 With one hand, lift front edge of the shelf from the front brackets.
- 2 With the other hand, reach under the shelf and bump rear edge of the shelf upward to disengage rear brackets.

Install a shelf

- 1 Insert shelf into chamber, placing it on brackets.
- 2 Gently bump rear edge of the shelf downward to engage brackets.
- 3 Pulling shelf forward gently; shelf should not disengage from rear brackets.

23.4 Move Slides and Brackets**Remove drawer slides**

- 1 Using a screwdriver, remove front bracket retainers.
- 2 Tap front brackets upward to disengage standards.
- 3 Remove slides from standards.

Install drawer slides

- 1 Insert slides into standard at appropriate height.
- 2 Tap front brackets downward to engage standards.
- 3 Using a screwdriver, install front bracket retainers.

Remove shelf brackets

- 1 Using a screwdriver, remove front bracket retainers.
- 2 Tap front brackets upward to disengage standards.
- 3 Remove front brackets from standards.

Install shelf brackets

- 1 Insert front brackets into standard at appropriate height.
- 2 Tap front brackets downward to engage standards.
- 3 Using a screwdriver, install front bracket retainers.

23.5 Optional Adapter Kits for Medication Dispensing Locks

Contact Helmer Technical Service or your distributor for service documentation pertaining to medication dispensing locks.

24 Settings

Through the Laboratory combined monitor and controller, current settings may be viewed and changed.

**NOTICE**

- ▶ Control Sensor Offset and Hysteresis settings are factory-preset and should not be changed unless directed by Helmer Technical Service.
- ▶ Changing temperature settings affects operation of the refrigerator. Do not change settings unless instructed by Helmer Technical Service.

24.1 Monitor and Controller Interface

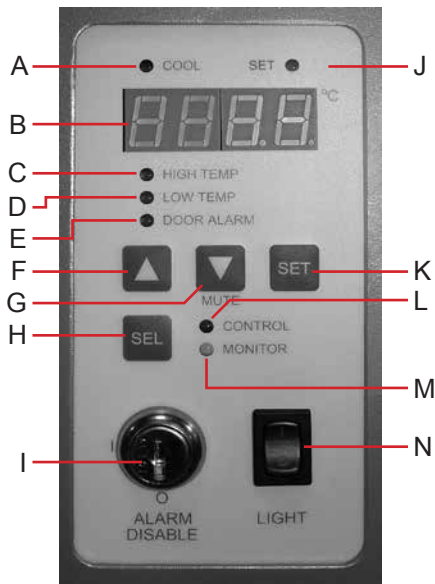

Label	Description	Function
A	COOL lamp	Indicates the compressor is running.
B	Display	Displays real-time temperature information, setpoints, and alarms.
C	HIGH TEMP lamp	Indicates when the refrigerator is in a high temperature alarm condition. Also indicates high alarm temperature setpoint is being changed.
D	LOW TEMP lamp	Indicates when the refrigerator is in a low temperature alarm condition. Also indicates low alarm temperature setpoint is being changed.
E	DOOR ALARM lamp	Indicates when the door is open.
F	UP ARROW button	Increases a temperature setting.
G	DOWN ARROW / MUTE ALARM button	Decreases a temperature setting. Also mutes the audible alarm for five minutes.
H	SEL button	Toggles between alarm monitor and control modes.
I	ALARM DISABLE key switch	Disables all audible alarms. This switch does not affect alarm lamps or signals sent through the remote alarm interface.
J	SET lamp	Indicates when temperature setpoint or alarm setpoint is being changed.
K	SET button	Allows settings to be selected, prior to changing settings.
L	CONTROL lamp	Indicates when the reading from the control temperature probe is displayed.
M	MONITOR lamp	Indicates when the display is showing temperature readings from the chamber probe. Also indicates when alarm setpoints are being changed.
N	LIGHT switch	Turns the chamber light on or off

NOTE The Alarm Disable key switch disables all audible alarms. This switch does not affect alarm lamps or signals sent through the remote alarm interface.

24.2 Refrigerator Setpoint

NOTE Default setpoint is 4.0 °C.

Change the setpoint if:

- ▶ Your organization requires a chamber temperature other than 4.0 °C.
- ▶ The normal chamber temperature is too high or low (after completing preventive maintenance and applicable troubleshooting tasks).

Confirm:

- ▶ Refrigerator has been placed per location requirements in the operation manual.
- ▶ Preventive maintenance has been completed per operation manual.
- ▶ Troubleshooting items associated with chamber temperature have been reviewed (if necessary).

Change setpoint.

- 1 Determine the change in value to reach desired setpoint. Adjustment should be the difference between current setpoint and new setpoint.

EXAMPLE

- ▶ Current setpoint is 4.0 °C
- ▶ Target setpoint is 5.0 °C
- ▶ Setpoint adjustment value is +1.0 °C

- 2 On the monitoring system, press and release **SEL** to change to Control mode. CONTROL lamp will illuminate.
- 3 Press and hold **SET** to display the reference temperature.
- 4 Hold **SET** and press **Up Arrow** or **Down Arrow** as necessary to set the adjustment value determined in step 2.
- 5 Release all buttons; the setpoint is changed.
- 6 Press and release **SEL** to return to Monitor mode. MONITOR lamp will illuminate.

24.3 Temperature Alarm Setpoints

View setpoints:

- 1 Hold **Up Arrow** and **Down Arrow** for three seconds. MONITOR lamp will flash to indicate entry into program mode.
- 2 Press **SEL** until desired setting appears.
- 3 Observe the setting.
- 4 To view another setting, press **SEL** again (optional).
- 5 Hold **Up Arrow** and **Down Arrow** for three seconds. MONITOR lamp stops flashing to indicate exit from program mode.

Flashing Lamp	Selected Setting
HIGH TEMP and MONITOR	High temp alarm setpoint
LOW TEMP and MONITOR	Low temp alarm setpoint
MONITOR only	Monitor offset
CONTROL only	Control sensor offset
CONTROL only	Control hysteresis

24.3.1 High Temperature Alarm

- ▶ Specifies the temperature at which the High Temperature Alarm activates.
- ▶ Default setpoint is 5.5 °C.
- ▶ Setpoint can be changed from -40.0 °C to +25.0 °C.

Change the setpoint:

- 1 Hold **Up Arrow** and **Down Arrow** for three seconds. MONITOR lamp will flash to indicate entry into program mode.
- 2 Press **SEL** until HIGH TEMP and MONITOR lamps flash.
- 3 Hold **SET**, then press **Up Arrow** or **Down Arrow** to change the setpoint.
- 4 Release **SET** button.
- 5 Hold **Up Arrow** and **Down Arrow** for three seconds. MONITOR lamp stops flashing to indicate exit from program mode. New settings are saved.

24.3.2 Low Temperature Alarm

- ▶ Specifies the temperature at which the Low Temperature Alarm activates.
- ▶ Default setpoint for HHB (blood bank) models is 1.5 °C.
- ▶ Default setpoint for HLR and HPR (laboratory and pharmacy) models is 2.0 °C.
- ▶ Setpoint can be changed from -40.0 °C to +25.0 °C.

Change the setpoint:

- 1 Hold **Up Arrow** and **Down Arrow** for three seconds. MONITOR lamp will flash to indicate entry into program mode.
- 2 Press **SEL** until LOW TEMP and MONITOR lamps flash.
- 3 Hold **SET**, then press **Up Arrow** or **Down Arrow** to change the setpoint.
- 4 Release **SET** button.
- 5 Hold **Up Arrow** and **Down Arrow** for three seconds. MONITOR lamp stops flashing to indicate exit from program mode. New settings are saved.

24.4 Temperature Calibration Setpoints
View setpoints:

- 1 Hold **Up Arrow** and **Down Arrow** for three seconds. MONITOR lamp will flash to indicate entry into program mode.
- 2 Press **SEL** until desired setting appears.
- 3 Observe the setting.
- 4 To view another setting, press **SEL** again (optional).
- 5 Hold **Up Arrow** and **Down Arrow** for three seconds. MONITOR lamp stops flashing to indicate exit from program mode.

Flashing Lamp	Selected Setting
HIGH TEMP and MONITOR	High temp alarm setpoint
LOW TEMP and MONITOR	Low temp alarm setpoint
MONITOR only	Monitor offset
CONTROL only	Control sensor offset
CONTROL only	Control hysteresis

24.4.1

Monitor Offset

- ▶ Adjust if temperature displayed on the monitor does not match measured chamber temperature.
- ▶ Value is factory-set to match an independent thermometer.
- ▶ Value can be changed from -10.0 °C to +10.0 °C.

NOTE

- ▶ If the variance is within acceptable limits, changing the offset value is optional.
- ▶ Probes in the bottle are connected to the monitoring system and sense chamber temperature. These probes do not affect refrigerator setpoint.

Obtain:

- ▶ Independent thermometer, calibrated and traceable per national standards.
- ▶ Tape, to attach thermometer to temperature probe.

Measure the chamber temperature:

- 1 Remove the probe from the probe bottle.
- 2 Unscrew the cap from the bottle.
- 3 Tape the thermometer to the temperature probe, and place them in the bottle. The probe and thermometer should be immersed at least 2" (50 mm).
- 4 Close the door and allow the chamber temperature to stabilize for 10 minutes.
- 5 Observe and note the thermometer temperature.
- 6 Remove thermometer and probe from bottle and remove tape.
- 7 Replace bottle cap, ensuring a tight fit.
- 8 Place the probe in bottle, immersing at least 2" (50 mm).

Enter the new offset value:

- ▶ Lower the offset value to lower the displayed monitor temperature.
- ▶ Raise the offset value to raise the displayed monitor temperature.

EXAMPLE

- ▶ Measured temperature (at the probe bottle) is 4.0 °C
- ▶ Displayed temperature is 4.5 °C
- ▶ Offset adjustment value is -0.5 °C

- 1 Hold **Up Arrow** and **Down Arrow** for three seconds. MONITOR lamp will flash to indicate entry into program mode.
- 2 Press **SEL** until only the MONITOR lamp flashes.
- 3 Hold **SET**, then press **Up Arrow** or **Down Arrow** to change the setpoint.
- 4 Release **SET** button.
- 5 Hold **Up Arrow** and **Down Arrow** for three seconds. MONITOR lamp stops flashing to indicate exit from program mode. New settings are saved.

24.4.2 Control Sensor Offset

The temperature controller senses chamber temperature through a probe in the unit cooler. The chamber setpoint typically varies from the measured temperature, so an offset value is used by the control system to compensate for the difference.

- ▶ Value is factory-preset and varies for each unit
- ▶ Offset value can be changed from -10.0 °C to +10.0 °C



NOTICE Control Sensor Offset is factory-preset and should not be changed unless directed by Helmer Technical Service.

24.4.3 Hysteresis

- ▶ Default setpoint for HLR111 and HPR111 models is 0.8 °C.
- ▶ Default setpoint for HLR/HPR 120, 125, 245, 256 models, and all HHB models is 2.0 °C.
- ▶ Allowable temperature variance on each side of the refrigerator setpoint.



NOTICE Hysteresis is factory-preset and should not be changed unless directed by Helmer Technical Service.

24.5 Test Alarms

Test alarms to ensure they are working correctly. The refrigerator has alarms for chamber temperature, power failure, and door open (time).

24.5.1 Chamber Temperature Alarm

IMPORTANT Perform the low alarm test before the high alarm test to control the temperature more closely and complete the testing more quickly.

Obtain:

- ▶ (1) 8 oz. (250 mL) glass half-full of chilled water.
- ▶ (1) glass filled with crushed ice.
- ▶ (1) 8 oz. (250 mL) glass half-full of warm water.



NOTICE Temperature probes are fragile; handle with care.

Test the low alarm:

- 1 Identify setting for low alarm setpoint.
- 2 Remove chamber temperature probe from bottle.
- 3 Immerse probe in chilled water.
- 4 While stirring probe in chilled water, add approximately one teaspoon (5 mL) of ice every 20 seconds. Ensure probe is at the bottom of the glass.
- 5 When low temperature alarm activates, note the temperature on the monitoring system display.

Test the high alarm:

- 1 Identify setting for high alarm setpoint.
- 2 While stirring probe in chilled water, add warm water so temperature increases 0.5 °C per minute.
- 3 When high temperature alarm activates, note the temperature on the monitoring system display.
- 4 Remove probe from warm water.
- 5 Place temperature probe in probe bottle, immersing it at least 2" (50 mm).

24.5.2 Power Failure Alarm

- 1 Disconnect the refrigerator from AC power. Audible power failure alarm will activate immediately and “PoFF” (power off) will appear on the display.
- 2 Reconnect the refrigerator to AC power. Audible power failure alarm will cease and “PoFF” will clear from the display.

24.5.3 Door Open Alarm

- ▶ Factory-set to three minutes.
- ▶ Value can not be changed.



NOTICE Before testing alarms, protect items in refrigerator from extended exposure to adverse temperature.

Test the alarm:

- 1 Open refrigerator door and note the time.
- 2 After three minutes, audible alarm will activate and DOOR ALARM lamp will flash.
- 3 Close refrigerator door. Audible door open alarm will cease and DOOR ALARM lamp will stop flashing.

25 Maintenance



- NOTICE**
- ▶ Before performing maintenance, protect items in refrigerator from extended exposure to adverse temperature.
 - ▶ Allow refrigerator temperature to stabilize at setpoint after performing service or after extended door opening.

NOTE Refer to the operation manual for the preventive maintenance schedule.

25.1 Recharge Refrigerant



- CAUTION**
- ▶ Review all safety instructions prior to recharging refrigerant. Refer to chapter 2 (Safety).
 - ▶ Maintenance should only be performed by trained refrigeration technicians.



NOTICE Use only non-CFC R-134A refrigerant.

Full initial refrigerant charge varies by model and power requirements, which can be found on the product specification label.

Model	Voltage	Initial Charge
111	Any	7.5 oz. (213 g)
120/125	Any	10.0 oz. (283 g)
245/256	115 V, 60 Hz	Contact Helmer Technical Service
	230 V, 50/60 Hz	20.0 oz. (567 g)

Obtain:

- ▶ Refrigerant
- ▶ Calibrated pressure gauge (0 psi to 25 psi (0 kPa to 175 kPa))

Add refrigerant:

- 1 Attach pressure gauge to the fittings on the refrigeration lines.
- 2 Monitor the low side (suction) pressure through a full compressor cycle.
- 3 Measure the pressure at the end of the next cycle, immediately before the compressor stops.

NOTE Pressure varies depending on ambient air temperature.

- 4 Add refrigerant. Check the pressure on the low side.
 - ▶ Low side = 16 psi to 18 psi (110 kPa to 125 kPa)
- 5 Remove pressure gauge.

25.2 Test Monitoring System Backup Battery

The monitoring system does not indicate the charge level of the battery. Regularly test the battery. Replace battery if the test fails or if the battery has been in use for one year.

Test backup battery:

- 1 Disconnect the refrigerator from AC power.
 - ▶ Screen should continue to display information without backlight.
 - ▶ If the display is blank, replace battery.
- 2 Reconnect the refrigerator to AC power.

25.3 Replace Monitoring system Backup Battery

On the top of the refrigerator, remove the battery and replace with a new battery.



NOTICE

When installing a replacement battery, use only a battery which meets the specifications outlined in chapter 25.7 (Supplies).

25.4 Replace the Fluorescent Lamps

- 1 Disconnect the refrigerator from AC power. Remove one battery from the monitoring system backup battery holder.
- 2 Single-door refrigerators: Remove drawers, shelves, baskets, and slides on the right side of the chamber.
- 3 Press short side of diffuser and unsnap it to remove from the light base.
- 4 Rotate defective light bulb and remove from the sockets.
- 5 Insert new light bulb into the sockets and rotate to lock into place.
- 6 Snap diffuser into the light base.
- 7 Reinstall the battery in the monitoring system backup battery holder. Reconnect the refrigerator to AC power.
- 8 Single-door refrigerators: Replace drawers, shelves, baskets, and slides.
- 9 Press the **MUTE** button to disable the high temperature alarm while refrigerator reaches operating temperature.

25.5 Clean the Refrigerator

25.5.1 Condenser Grill

In environments where refrigerator is exposed to excessive lint or dust, condenser grill may require cleaning more frequently than stated in preventive maintenance schedule.

Clean the condenser grill using a soft brush and a vacuum cleaner.

25.5.2 Exterior

Clean exterior surfaces with soft cotton cloth and non-abrasive liquid cleaner.

25.5.3 Interior

Clean painted surfaces with mild detergent. Clean stainless steel surfaces with a general-purpose laboratory cleaner suitable for stainless steel.

25.5.4 Door Gaskets

Clean with soft cloth and mild soap and water solution.

25.5.5 Clean and Refill Probe Bottle

NOTE A kit that includes a probe bottle and glycerin is available from Helmer.

Obtain:

- ▶ Fresh water-bleach solution (not provided)
 - ▶ 1:9 ratio of bleach to water
 - ▶ Bleach is 5% solution of commercial sodium hypochlorite (NaOCl)
 - ▶ Equivalent oxidizing cleaner/disinfectant approved by your organization may be substituted
- ▶ 4 oz. (120 mL) of product simulation solution per bottle
 - ▶ 10:1 ratio of water to glycerin

Clean and refill bottle:

- 1 Remove probe from bottle.
- 2 Remove bottle from bracket.
- 3 Clean bottle with water-bleach solution.
- 4 Fill bottle with 4 oz. (120 mL) of product simulation solution.
- 5 Cap bottle tightly to minimize evaporation.
- 6 Place bottle in bracket.
- 7 Replace probe, immersing at least 2" (50 mm).

25.6 Unit Cooler Cover Removal and Installation

If unit cooler cover is not removed as detailed in this procedure the drain port may be damaged. Improper drainage may result in excessive icing and refrigerator's inability to maintain temperature.

Required tools:

- ▶ 5/16" socket wrench
- ▶ Tool to push putty away from the drain hose

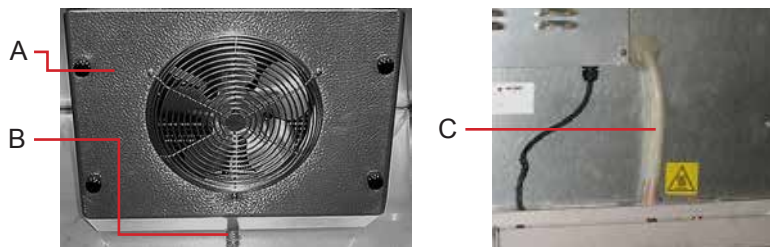

Drain line and hose.

Label	Description
A	Unit cooler cover
B	Drain port
C	Drain hose

25.6.1 Remove the Unit Cooler Cover



WARNING Disconnect the refrigerator from AC power when removing the unit cooler.



CAUTION The condensate evaporator and water evaporation tray are hot.

- 1 Disconnect the refrigerator from AC power. Remove one battery from the monitoring system backup battery holder.
- 2 Remove top drawer, basket, or shelf from the chamber.
- 3 On the back of the chamber, peel putty back to expose drain hose (C).
- 4 Remove drain hose from unit cooler drain port (B).
 - a Pull drain hose downward to separate from unit cooler.
 - b Twist drain hose while pulling to assist in removal.
- 5 Push the drain hose (C) out through rear of chamber.
- 6 Remove the unit cooler cover.
 - a Hold unit cooler cover in place to prevent it from dropping.
 - b Use the socket wrench to remove four screws securing the unit cooler cover.
 - c Carefully lower unit cooler cover to avoid damage to the fan wiring.

25.6.2 Install the Unit Cooler Cover

- 1 Verify unit cooler wiring is connected and routed correctly.
 - a Wiring should be routed above copper tube inside the unit cooler.
 - b Reconnect wires if they have separated.
- 2 Attach unit cooler cover.
 - a Lift unit cooler cover into place.
 - b Front edge of the cover should be behind the unit cooler case.
 - c Use the socket wrench to install four screws to secure the unit cooler cover.
- 3 Insert the drain hose through hole in the refrigerator.
 - a Push drain hose upward, toward the unit cooler drain port.
 - b In the chamber, push drain hose onto unit cooler drain port.
- 4 On the back of the chamber, press putty around the drain hose.
- 5 Reinstall the top drawer, shelf, or basket.
- 6 Reinstall the battery in the monitoring system backup battery holder. Reconnect the refrigerator to AC power.
- 7 Press the **Mute** button to disable the high temperature alarm while refrigerator reaches operating temperature.

25.7 Supplies

Refrigerant: non-CFC, R-134A

Chart paper: 220366 (52 sheets)

Glycerin solution: 400922-1

Fluorescent lamp: T5, 13 W

Monitoring system battery: (1) 9 V, non-rechargeable lithium battery (or equivalent): 120399

Chart recorder battery (optional): (1) 9 V non-rechargeable alkaline (or equivalent): 120218

26 Troubleshooting



- CAUTION**
- ▶ Review all safety instructions prior to troubleshooting. Refer to chapter 2 (Safety).
 - ▶ Troubleshooting should only be performed by trained refrigeration technicians.

26.1 General Operation Problems

Problem	Possible Cause	Action
Drawer or basket does not slide easily.	Drawer slide is faulty.	▶ Confirm the slide is operating correctly. Replace if necessary.
	Debris in the drawer slides.	▶ Pull the drawer or basket out and confirm the slides are free of debris. Clean if necessary.
	Drawer slides are not lubricated.	▶ Using a lightweight oil, lubricate the bearings in the slides.
	Drawer or basket is misaligned or not level.	▶ Confirm both slides for the drawer or basket are mounted at the same height.
Door does not open easily.	Debris in the hinges.	▶ Confirm the hinges are free of debris. Clean the hinges if necessary.
	Door hinges are not lubricated.	▶ Using a general-purpose grease, lubricate the pivots in the hinges.
	Hinge cam is faulty.	▶ Confirm the hinge cam is not damaged. Replace if necessary.
Chamber temperature meets an alarm condition, but the appropriate temperature alarm is not active.	Temperature alarm setpoint was changed.	▶ Check the current setpoints for the temperature alarms. Change the setpoints if necessary.

26.2 Chamber Temperature Problems

Problem	Possible Cause	Action
“Prob” appears on the display, but the chamber temperature is set correctly.	Chamber temperature probe connection is loose.	▶ Check the continuity of the probe wiring and connection. Secure the connection or replace the probe if necessary.
	A component is faulty or internal connections are loose.	▶ Contact Helmer Technical Service.
Chamber temperature does not stabilize at the refrigerator setpoint.	Compressor starting relay is faulty.	▶ Confirm the relay is operating correctly. Replace the relay if necessary.
	Monitor/control board is faulty.	▶ Confirm the monitor/control board is operating correctly. Replace the board if necessary.
	Condensing unit fan is not running.	▶ Check the condensing unit fan connections. Replace the fan motor if necessary.
	Unit cooler fan is not running.	▶ Check the voltage to the fan when door switch is activated. Replace the fan motor or door switch if necessary.
	Compressor motor has seized.	▶ Replace the compressor.
	Temperature control probe is faulty.	▶ Confirm the probe is providing resistance in the range of 98 Ω to 110 Ω. Replace the probe if necessary.
	Refrigerant level is too low.	▶ Check the refrigeration lines for leaks and repair them if necessary. ▶ Check the refrigerant level. Recharge the refrigerant if necessary.
	Condenser grill is dirty.	▶ Check the condenser grill. Clean it if necessary.
	Circulation at the top of the chamber is not adequate.	▶ Check if there are any items that may obstruct air flow and remove them if necessary.
	Ambient air temperature is too high.	▶ Confirm the refrigerator is placed appropriately. Refer to the operation manual.
	A component is faulty or internal connections are loose.	▶ Contact Helmer Technical Service.
Probe bottle is empty, or solution is too low.	▶ Check the level of product simulation solution in the bottle. Refill the bottles if necessary.	

Problem	Possible Cause	Action
Compressor runs continuously.	Refrigerator setpoint is set too low.	▶ Confirm the setpoint is set within the operating range. Change the setpoint if necessary.
	Temperature control probe is faulty.	▶ Confirm the probe is providing resistance in the range of 98 Ω to 110 Ω. Replace the probe if necessary.
	Monitor/control board is faulty.	▶ Confirm the monitor/control board is operating correctly. Replace the board if necessary.
	Compressor starting relay is faulty.	▶ Confirm the relay is operating correctly. Replace it if necessary.
	Defrost timer is faulty (HLR and HPR models).	▶ Replace the defrost timer.

26.3

Alarm Activation Problems

Problem	Possible Cause	Action
Refrigerator is in an alarm condition, but alarms are not audible.	Alarm system is faulty.	▶ Confirm the circuit board and line connections are functioning correctly.
	Monitor/control board is faulty.	▶ Replace the monitor/control board.
	Alarm buzzer is faulty.	▶ Replace the alarm buzzer.
	Audible alarms have been muted.	▶ Verify audible alarms are not muted.
	A component is faulty or internal connections are loose.	▶ Contact Helmer Technical Service.
Refrigerator meets an alarm condition, but the appropriate alarm is not active.	Monitor/control board is faulty.	▶ Replace the monitor/control board.
	Alarm setpoint was changed.	▶ Check the current setpoints for the alarms. Change the setpoints if necessary.
	A component is faulty or internal connections are loose.	▶ Contact Helmer Technical Service.

Problem	Possible Cause	Action
High Temperature alarm activates when the door is opened, then clears shortly after the door is closed.	Chamber temperature probe connection is loose.	▶ Test the probe connections. Secure the connections if necessary.
	Chamber temperature probe is faulty.	▶ Test the probe. Replace the probe if necessary.
	Unit cooler fan continues to run while the door is open.	▶ Test the door switch and unit cooler fan connections. Secure the connections if necessary. Replace the door switch or fan motor if necessary.
	Probe bottle is empty.	▶ Check level of product simulation solution in the bottle. Refill bottles if needed.
	High temperature alarm setpoint is set too low.	▶ Check the setpoint. Change the setpoint if necessary.
	A component is faulty or internal connections are loose.	▶ Contact Helmer Technical Service.
Refrigerator is connected to power, but the AC Power Failure alarm is active.	Outlet connection is faulty.	▶ Verify power at the outlet. Repair the original outlet or connect to a different outlet if necessary.
	Power cord is faulty.	▶ Confirm the power cord is connected securely. Secure the power cord if necessary.
	Temperature control transformer is faulty.	▶ Replace the temperature control transformer.
	Circuit breaker was tripped (230 V models).	▶ Confirm the circuit breaker is seated. Push the circuit breaker to reset it if necessary.
	A component is faulty or internal connections are loose.	▶ Contact Helmer Technical Service.
Door Open alarm is activating sporadically.	Door(s) not closing completely.	▶ Confirm the hinge cams are not damaged. Replace the hinge cams if necessary.
	Door(s) closing but not sealing completely.	▶ Confirm the door gasket seals completely. Replace the door gasket if necessary.
	Door switch connection(s) is faulty.	▶ Test the switch connections. Secure the connections if necessary.
	One or both door switches are faulty.	▶ Replace the door switch(s).
	Monitor/control board is faulty.	▶ Replace the monitor/control board.
All alarms are activating sporadically.	Alarm system is faulty.	▶ Confirm the circuit board and line connections are functioning correctly.
	A component is faulty or internal connections are loose.	▶ Contact Helmer Technical Service.
	Monitor/control board is faulty.	▶ Replace the monitor/control board.

Problem	Possible Cause	Action
An alarm activated, but the temperature recorded at activation does not match the alarm setpoint.	Temperature changed slightly around the time of activation.	▶ No action needed.

26.4
Condensation Problems

Problem	Possible Cause	Action
Excessive water in the water evaporation tray.	Heater in the evaporation tray is faulty.	<ul style="list-style-type: none"> ▶ Confirm the heater is hot and is drawing the appropriate current. ▶ For 115 V refrigerators, the current should be approximately 0.43 A to 0.55 A. ▶ For 230 V refrigerators, the current should be approximately 0.21 A to 0.35 A.
	Humid air is entering the chamber.	<ul style="list-style-type: none"> ▶ Confirm the refrigerator is level, and the doors are aligned, closing tightly, and sealing correctly. ▶ Contact Helmer Technical Service to correct issues as necessary.
Excessive water in the chamber.	Humid air is entering the chamber.	▶ Confirm the refrigerator is level, and the doors are aligned, closing tightly, and sealing correctly. Correct issues as necessary.
	Connection between the unit cooler and the drain tube is loose.	▶ Confirm the connection is secure. Tighten the connection if necessary.
	Defrost timer is faulty (HLR and HPR models).	▶ Replace the defrost timer.
	Drain line is plugged.	▶ Confirm the drain tube is free of debris. Remove debris if necessary.
Excessive humidity on the doors.	Humid air is entering the chamber.	▶ Confirm the refrigerator is level, and the doors are aligned, closing tightly, and sealing correctly. Correct issues as necessary.
	Relative humidity around the refrigerator is too high.	▶ Confirm the refrigerator is placed properly. Refer to the operation manual.

27 Parts



NOTICE

- ▶ Before replacing parts, protect items in refrigerator from extended exposure to adverse temperature.
- ▶ Allow refrigerator temperature to stabilize at setpoint after replacing parts or after extended door opening.

27.1 Front

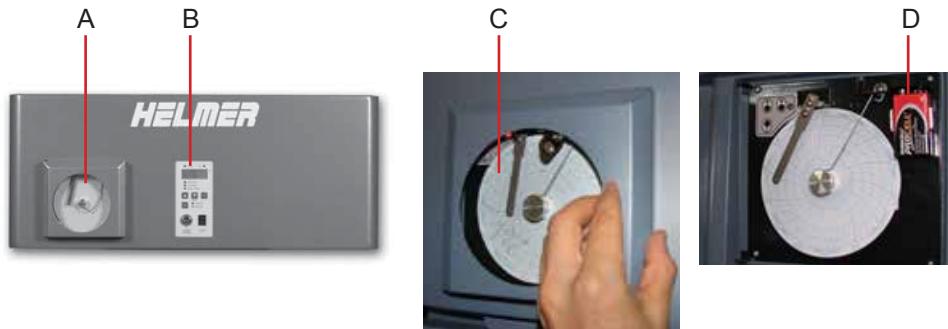

Front features.

Label	Description	Part Number	Schematic Label
A	Chart recorder and chart recorder door	400409-2	X
B	Laboratory display	Refer to subsequent section(s) for part numbers	L
C	Chart paper	220366 (package of 52 sheets)	-
D	Chart recorder backup battery (9 V alkaline, non-rechargeable)	120218	AD
Not shown	Caster (swivel with brake)	Serial number 974891 and earlier: 220380 Serial number 947892 and later: 220467	-

27.1.1 Laboratory Display

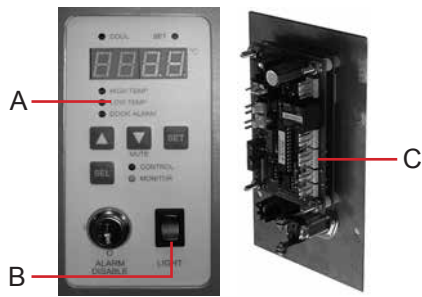

Left: Laboratory display with touchpad. Right: Rear view of display showing monitor/control board.

Label	Description	Part Number	Schematic Label
A	Touchpad	320770-1	-
B	Light switch	120202	AJ
C	Monitor/control board	120402	L

27.2 Top

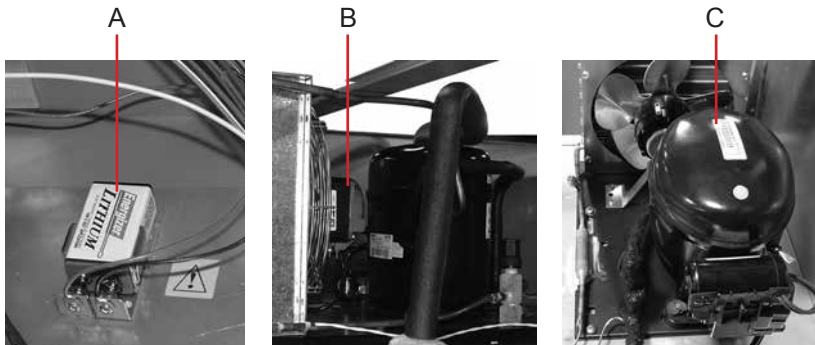

Top features.

Label	Description	Part Number	Schematic Label
A	Monitoring system backup battery	120399	AE
B	Compressor unit	Contact Helmer	A
C	Condensing unit fan motor	Contact Helmer	U

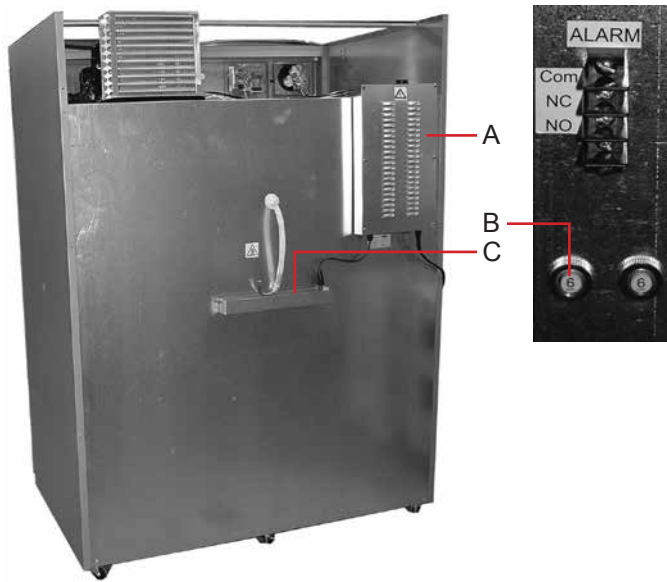

Rear features.

Label	Description	Part Number	Schematic Label
A	Electrical box	Refer to subsequent section(s) for part numbers	-
B	Circuit breaker, 6 A	Single-door 230 V models: 120429	P
	Circuit breaker, 7 A	Double-door 230 V models: 120428	P
C	Condensate evaporator kit (Includes the condensate evaporator and water evaporation tray)	115 V: 111 models: 400791-1 120, 125, 245, and 256 models: 400790-1 230 V: 111 models: 400791-2 120, 125, 245, and 256 models: 400790-2	J

27.3.1 Electrical Box

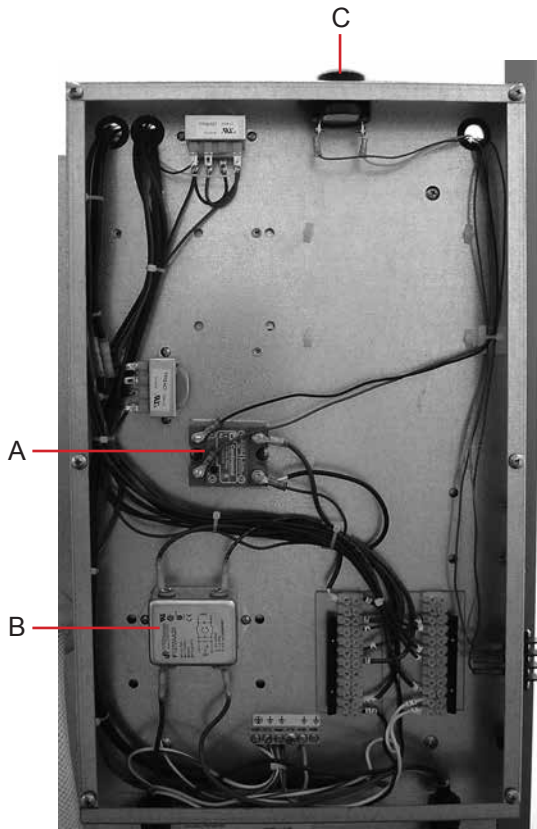

Electrical box features (HHB120 model shown).

Label	Description	Part Number	Schematic Label
A	Compressor relay	120426	AA
B	Power line filter	120400	AK
C	Alarm buzzer	120160	D
Not shown	Defrost timer (HLR and HPR models)	111 models: 120556 120, 125, 245,256 models: 800127-1	F



Interior features.

Label	Description	Part Number	Schematic Label
A	Chart recorder probe	400855-1	AI
B	Chamber probe	HB model: 401096-1 HPR, HLR, and HHB models: 400512-1	AB
C	Probe bottle and glycerin kit	400922-1	-
D	Unit cooler	Refer to subsequent section(s) for part numbers	AG
E	Door switch	120380	I
F	Door	Refer to subsequent section(s) for part numbers	-
G	Storage parts	Refer to subsequent section(s) for part numbers	-
H	Lamp assemblies	Refer to subsequent section(s) for part numbers	M

27.4.1 Lighting

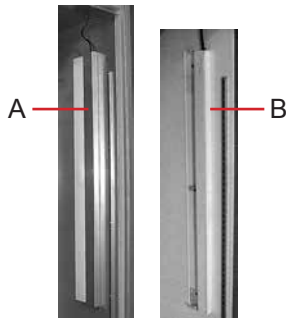

Light features.

Label	Description	Part Number	Schematic Label
A	Light assembly (models with stainless steel interior)	115 V: 400508-1 230 V: 400508-2	M
B	Light assembly (models with powder-coated interior)	115 V: 400507-2 230 V: 400507-1	M
Not shown	Light bulb	120409	-

27.4.2 Unit Cooler

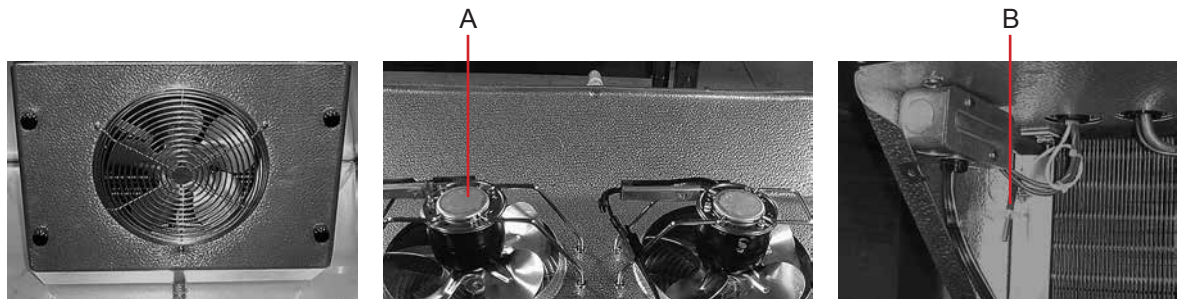

Left: Unit cooler (single-door model shown). Center and right: Unit cooler parts.

Label	Description	Part Number	Schematic Label
A	Unit cooler fan motor	115 V 111 models: 120540 120 and 125 models: 120411 245 and 256 models (one fan): 120587 245 and 256 models (two fans): 120410 230 V 111 models: 120560 120 and 125 models: 120415 245 and 256 models (one fan): 120588 245 and 256 models (two fans): 120545	H
B	Temperature control probe	HPR, HLR, and HHB models: 400511-1	G

27.4.3 Storage



Storage features.

Label	Description	Part Number
A	Half shelf (includes hardware)	120, 125, 245, 256 models: 400413-1
B	Full shelf (includes hardware)	111 models: 400414-3 120 and 245 models: 400414-1 125 and 256 models: 400414-2
C	Roll out basket assembly (includes 2 slides, and hardware)	111 models: 400751-1 120 and 245 models: 400415-1 125 and 256 models: 400415-2
D	Drawer assembly (includes 2 slides and hardware)	111 models: 400752-2 120 and 245 models: 400370-3 125 and 256 models: 400370-4
Not shown	Slide assembly (includes 2 slides)	111 models: 400753-1 120 and 245 models: 400714-1 125 and 256 models: 400714-2
	Pole mast for chromatography (HLR model with chromatography option)	400478-1

27.4.4

Door and Hinge



Door and hinge parts.

Label	Description	Part Number
A	Door lock	220374
B	Door handle pad	320684-1
C	Hinge bearing	220375
D	Upper hinge bracket	Right hinge: 400376-1 Left hinge: 400376-2
E	Door gasket	111 models: 321082-1 120, 125, 245, and 256 models: 320726-1
F	Hinge cam	320742-1
G	Door stop	320763-1
H	Lower hinge bracket	Right hinge: 400377-1 Left hinge: 400377-2

28 Schematics

28.1 HLR and HPR Models; 11 Cubic Feet

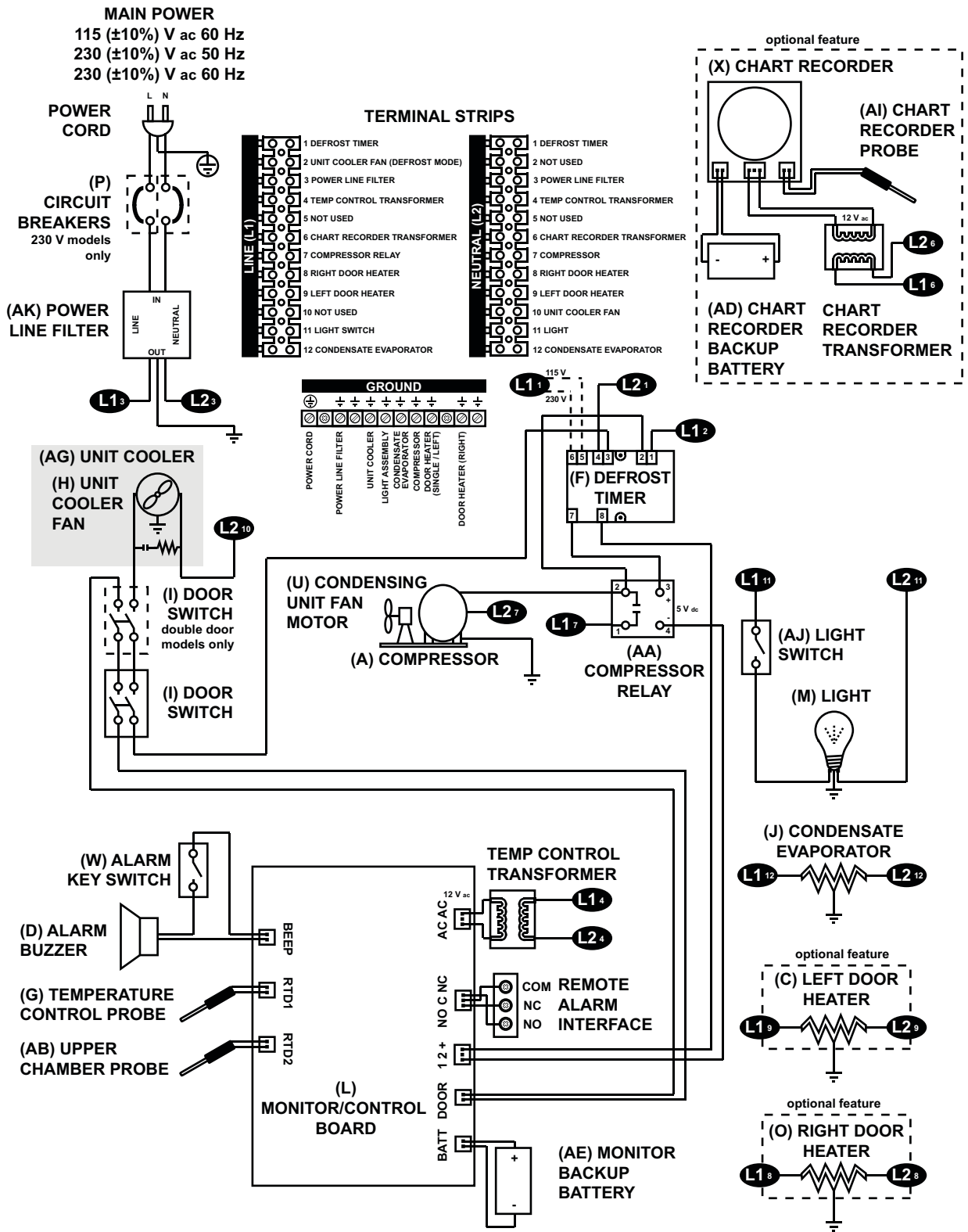

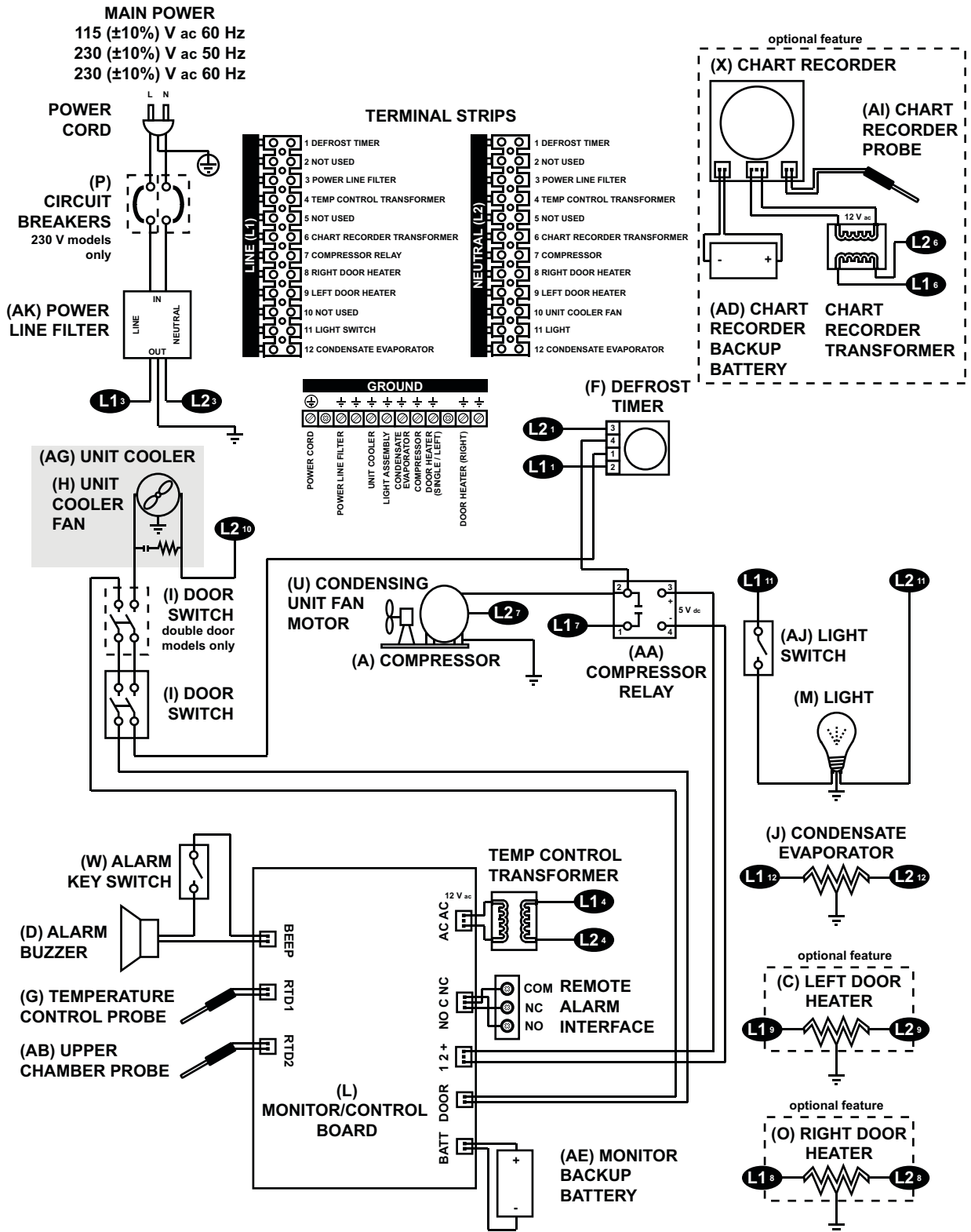

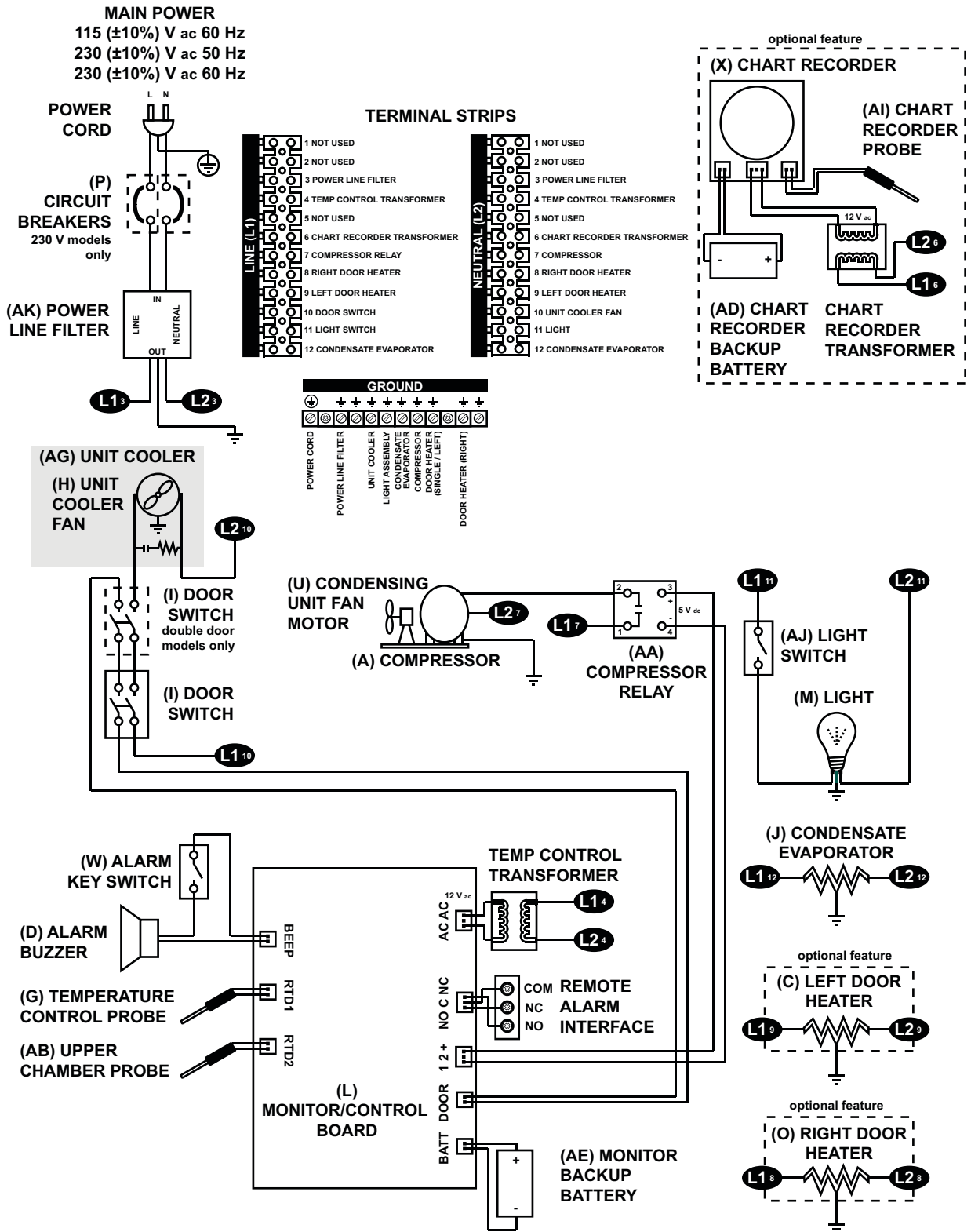

END OF MANUAL

HELMER SCIENTIFIC
14400 Bergen Boulevard
Noblesville, IN 46060 USA

PH +1.317.773.9073
FAX +1.317.773.9082
www.helmerinc.com

