

Model i.Series® iLR245 Upright Laboratory Refrigerator

Specifications

Application, Rating and Electrical Data	
Application	Storage of medical and scientific products
Storage Volume	44.9 cu ft (1271 L)
Temperature Range	2° to 10°C
Electrical Power	115V 60Hz 230V 50Hz 230V 60Hz
Maximum Current	11.5 FLA / 6.0 FLA / 6.0 FLA
Building Supply Rating	15 amp dedicated ground circuit
Power Plug / Power Cord Length	NEMA 5-15 hospital grade plug (115V) CEE 7/7 plug (230V 50Hz) NEMA 6-15 hospital grade plug (230V 60Hz) 8-10 ft (2439-3048 mm)
Certification / Agency Listing	QPS (Certified to UL and CSA Standards) ENERGY STAR® certified (115V)
Indoor/Outdoor Use	Indoor use only
Application Environment	Non-corrosive, non-flammable, non-explosive, 15°C to 32°C (59°F to 90°F)
Refrigeration System	
Refrigeration System	Forced-air circulation
Compressor / Number	.5 HP hermetic / 1
Condenser Type / Number	Air-cooled fin and tube / 1
Expansion Device	Cap tube
Evaporator Type	Air-cooled fin and tube
Defrost Method	Automatic
Refrigerant Charge	R134A Non-CFC
Performance Data	
Uniformity	+/-1.5°C at 4°C Setpoint
Warranty	
Rel.i™ Plus (US/Canada)	7 years compressor, 2 years parts, 1 year labor
Outside US/Canada	Consult your local representative

Controller	
Interface	i.C³ eye-level, color touchscreen
Power Switch	On/Off - All Circuit breaker - 230V only
Controller Type	Microprocessor with touchscreen input and display. Includes USB port for data retrieval.
Security	Lockable door, password protected settings
Control Sensor	RTD
Communication Ports	(2) USB Ports (1) RJ45 Hub (1) RS232 Port (optional)
High / Low Alarms	Fully adjustable
High / Low Alarm Test	Automatic (Peltier)
Door Ajar Alarm	Fully adjustable
Power Failure Alarm	Yes
Condenser Temperature Alarm	Fully adjustable
Event Log	All alarms, door openings, download via USB
Temperature Log	60 days, download via USB
Interactive Temperature Graph	Yes
Min/Max Display and Reset	Yes
Battery Back-up	20 hour display and alarm battery back-up for i.C³ touchscreen (rechargeable 12V, lead acid battery)

Dimensions and Construction	
Interior (w x h x d)	55 x 58.25 x 24.25 in 1397 x 1480 x 616 mm
Exterior (w x h x d)	59.25 x 79.5 x 29.5 in 1505 x 2020 x 750 mm
Overall Exterior (w x h x d) (Includes door handles, electrical panel, and evaporation tray)	59.25 x 79.5 x 32.5 in 1505 x 2020 x 826 mm
Insulation	Minimum of 2" (51mm) non-CFC foamed urethane insulation
Exterior / Interior Finish	Bacteria-resistant powder coating
Doors	2, Dual-pane glass
Access Ports	Sidewall with interior and exterior plugs Top for external monitoring probe(s)
Interior Storage / Capacity	8 epoxy coated shelves 22 x 23 in (559 x 585 mm) 100 lbs (46 kg) max capacity / shelf
Lighting	Adjustable LED Auto-on, on/off switch
Casters	Standard / swivel locking
Net Weight	702 lb (319 kg)
Shipping Weight	822 lb (373 kg)
Clearance Requirements	Minimum of 8" (203mm) above and 3" (76mm) behind unit.
Options / Accessories	Chart Recorder, Floor & Wall Bracket Kit, Remote Alarms, Leveling Feet, Stainless Steel Interior, Extended Warranty



Technical Data Sheet

Laboratory Refrigerator

i.Series® iLR245

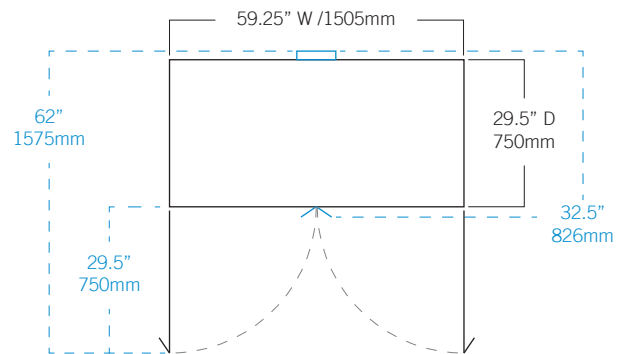
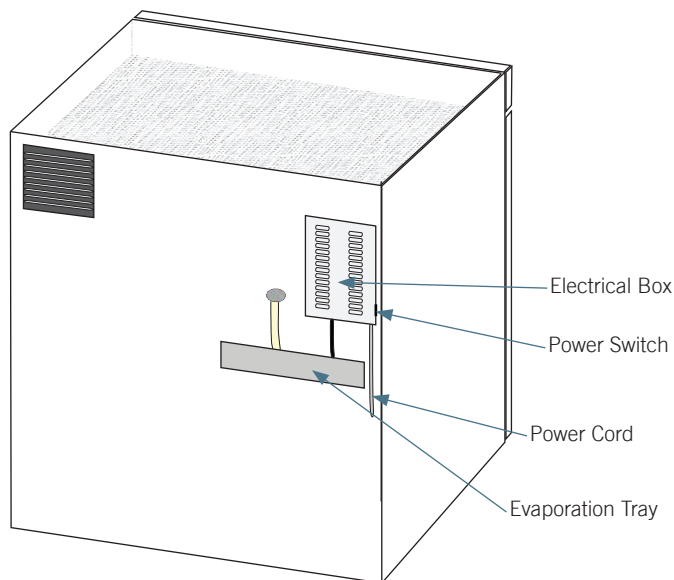
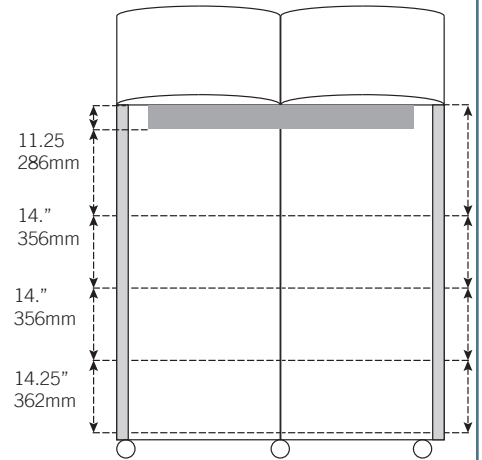
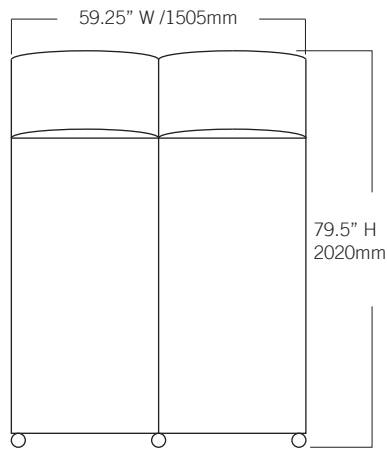

Helmer Scientific | 14400 Bergen Boulevard | Noblesville, IN 46060 | USA
 +1.317.773.9073 | www.helmerinc.com



© 2016-2017 Helmer Inc. All rights reserved. 380317-1/E 5/17
 All trademarks are the property of Helmer Scientific. Specifications subject to change.