

Model

i.Series® iB456 Pass-Thru Refrigerator

Specifications

Application, Rating and Electrical Data

Application	Storage of blood and other medical and scientific products
Storage Volume	58 cu ft (1642 L)
Storage Capacity	864 (450 ml bags)
Temperature Range	2° to 10°C
Electrical Power	115V 60Hz 230V 50Hz 230V 60Hz
Maximum Current	13.25 FLA / 7.8 FLA / 8.2 FLA
Building Supply Rating	15 amp dedicated ground circuit
Power Plug / Power Cord Length	NEMA 5-15 hospital grade plug (115V) CEE 7/7 plug (230V 50Hz) NEMA 6-15 hospital grade plug (230V 60Hz) 8-10 ft (2439-3048 mm)
Certification / Agency Listing	QPS (Certified to UL and CSA Standards)
Indoor/Outdoor Use	Indoor use only
Application Environment	Non-corrosive, non-flammable, non-explosive, 15°C to 32°C (59°F to 90°F)

Refrigeration System

Refrigeration System	Forced-air circulation
Compressor / Number	.5 HP hermetic / 1
Condenser Type / Number	Air-cooled fin and tube / 1
Expansion Device	Cap tube
Evaporator Type	Air-cooled fin and tube
Defrost Method	Automatic
Refrigerant Charge	R134A Non-CFC

Performance Data

Uniformity	+/-1°C at 4°C Setpoint
------------	------------------------

Warranty

Rel.i™ Plus (US/Canada)	7 years compressor, 2 years parts, 1 year labor
Outside US/Canada	Consult your local representative

Controller

Interface	i.C ³ ® eye-level, color touchscreen
Power Switch	On/Off - All Circuit breaker - 230V only
Controller Type	Microprocessor with touchscreen input and display. Includes USB port for data retrieval.
Security	Lockable door, password protected settings
Control Sensor	RTD
Communication Ports	(2) USB Ports (1) RJ45 Hub (1) RS232 Port (optional)
High / Low Alarms	Fully adjustable
High / Low Alarm Test	Automatic (Peltier)
Door Ajar Alarm	Fully adjustable
Power Failure Alarm	Yes
Condenser Temperature Alarm	Fully adjustable
Event Log	All alarms, door openings, download via USB
Temperature Log	60 days, download via USB
Interactive Temperature Graph	Yes
Min/Max Display and Reset	Yes
Battery Back-up	20 hour display and alarm battery back-up for i.C ³ ® touchscreen (rechargeable 12V, lead acid battery)

Dimensions and Construction

Interior (w x h x d)	55 x 58.25 x 32 in 1397 x 1480 x 813 mm
Exterior (w x h x d)	59.25 x 80 x 36 in 1505 x 2032 x 915 mm
Overall Exterior (w x h x d) (Includes door handles)	59.25 x 80 x 40 in 1505 x 2032 x 1016 mm
Insulation	Minimum of 2" (51mm) non-CFC foamed urethane insulation
Exterior / Interior Finish	Bacteria-resistant powder coating
Doors	4, Dual-pane glass
Access Ports	Top for external monitoring probe(s)
Interior Storage / Capacity	12 stainless steel drawers 22 x 27 in (559 x 686 mm) 100 (46) max capacity / drawer
Lighting	Adjustable LED Auto-on, on/off switch
Casters	Standard / swivel locking
Net Weight	852 lbs (387 kg)
Shipping Weight	977 lbs (444 kg)
Clearance Requirements	Minimum of 8" (203mm) above the control side of the refrigerator. Clearance above the clean room side may be 0". Top enclosure cannot be placed more than 11" (280mm) from the front (clean room side) of the refrigerator.
Options / Accessories	Interlock Door- Electronically Controlled,Skirt, Finish Trim Kit, Remote Alarms, Floor Bracket Kit, Stainless Steel Interior, Extended Warranty.



Technical Data Sheet

Blood Bank Pass-Thru Refrigerator

i.Series® iB456

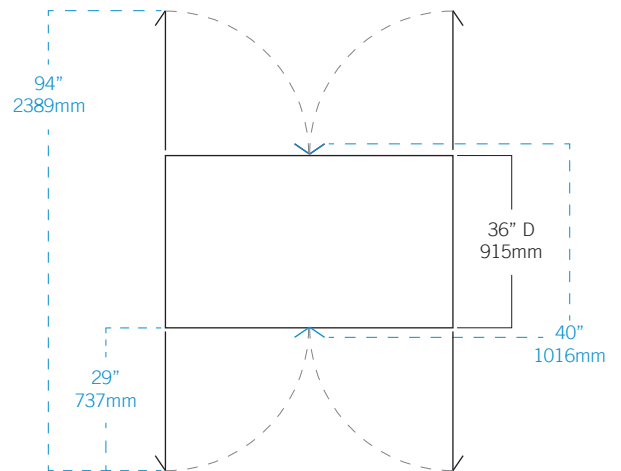
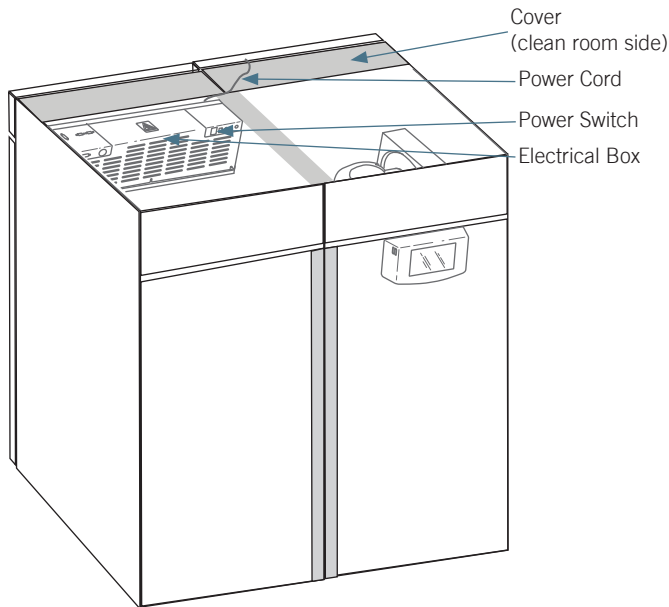
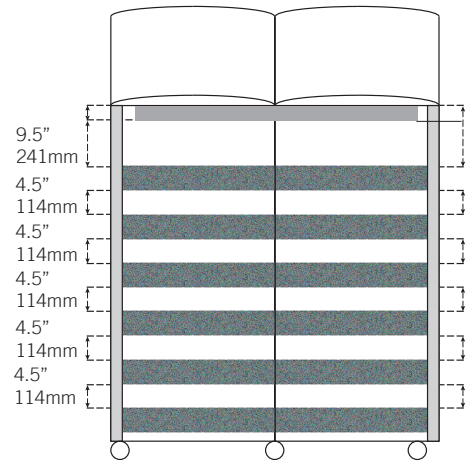
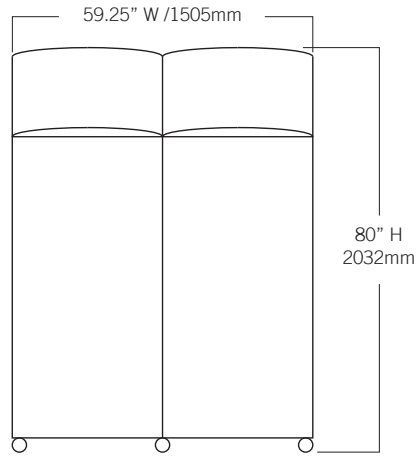

Helmer Scientific | 14400 Bergen Boulevard | Noblesville, IN 46060 | USA
 +1.317.773.9073 | www.helmerinc.com



© 2016-2019 Helmer Inc. All rights reserved. 380302-1/E 2/19
 All trademarks are the property of Helmer Scientific. Specifications subject to change.