

Model i.Series® iB125 Upright Blood Bank Refrigerator

Specifications

Application, Rating and Electrical Data	
Application	Storage of blood and other medical and scientific products
Storage Volume	25.2 cu ft (714 L)
Storage Capacity	504 (450 ml bags)
Temperature Range	2° to 10°C
Electrical Power	115V 60Hz 230V 50Hz 230V 60Hz
Maximum Current	7.5 FLA / 4.2 FLA / 4.2 FLA
Building Supply Rating	15 amp dedicated ground circuit
Power Plug / Power Cord Length	NEMA 5-15 hospital grade plug (115V) CEE 7/7 plug (230V 50Hz) NEMA 6-15 hospital grade plug (230V 60Hz) 8-10 ft (2439-3048 mm)
Certification / Agency Listing	QPS (Certified to UL and CSA Standards) ENERGY STAR® certified (115V)
Indoor/Outdoor Use	Indoor use only
Application Environment	Non-corrosive, non-flammable, non-explosive, 15°C to 32°C (59°F to 90°F)
Refrigeration System	
Refrigeration System	Forced-air circulation
Compressor / Number	.33 HP hermetic / 1
Condenser Type / Number	Air-cooled fin and tube / 1
Expansion Device	Cap tube
Evaporator Type	Air-cooled fin and tube
Defrost Method	Automatic
Refrigerant Charge	R134A Non-CFC
Performance Data	
Uniformity	+/-1°C at 4°C Setpoint
Warranty	
Rel.i™ Plus (US/Canada)	7 years compressor, 2 years parts, 1 year labor
Outside US/Canada	Consult your local representative

Controller	
Interface	i.C³ eye-level, color touchscreen
Power Switch	On/Off - All Circuit breaker - 230V only
Controller Type	Microprocessor with touchscreen input and display. Includes USB port for data retrieval.
Security	Lockable door, password protected settings, optional PIN access
Control Sensor	RTD
Communication Ports	(2) USB Ports (1) RJ45 Hub (1) RS232 Port (optional)
High / Low Alarms	Fully adjustable
High / Low Alarm Test	Automatic (Peltier)
Door Ajar Alarm	Fully adjustable
Power Failure Alarm	Yes
Condenser Temperature Alarm	Fully adjustable
Event Log	All alarms, door openings, download via USB
Temperature Log	60 days, download via USB
Access Log	60 days, download via USB
Interactive Temperature Graph	Yes
Min/Max Display and Reset	Yes
Battery Back-up	20 hour display and alarm battery back-up for i.C³ touchscreen (rechargeable 12V, lead acid battery)

Dimensions and Construction	
Interior (w x h x d)	24.75 x 58.25 x 30.25 in 629 x 1480 x 769 mm
Exterior (w x h x d)	29.5 x 79.5 x 35.5 in 750 x 2020 x 902 mm
Overall Exterior (w x h x d) (Includes door handle, electrical panel, and evaporation tray)	29.5 x 79.5 x 38.5 in 750 x 2020 x 978 mm
Insulation	Minimum of 2" (51mm) non-CFC foamed urethane insulation
Exterior / Interior Finish	Bacteria-resistant powder coating
Doors	1, Dual-pane glass
Access Ports	Top for external monitoring probe(s)
Interior Storage / Capacity	7 stainless steel drawers 22 x 27 in (559 x 686 mm) 100 lb (46 kg) max capacity / drawer
Lighting	Adjustable LED Auto-on, on/off switch
Casters	Standard / swivel locking
Integrated Access Control	Optional - Electromagnetic lock via i.C³ User Interface PIN
Net Weight	559 lb (254 kg)
Shipping Weight	649 lb (295 kg)
Clearance Requirements	Minimum of 8" (203mm) above and 3" (76mm) behind unit.
Options / Accessories	Floor & Wall Bracket Kit, Remote Alarms, Leveling Feet, Stainless Steel Interior, Remote Lock Adapter Kit, Extended Warranty

Technical Data Sheet

Blood Bank Refrigerator

i.Series® iB125

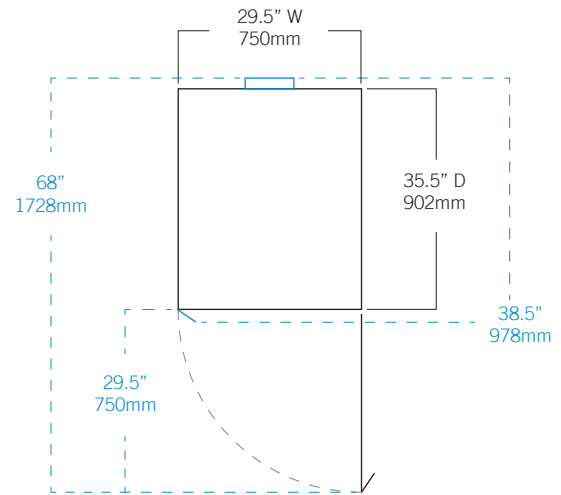
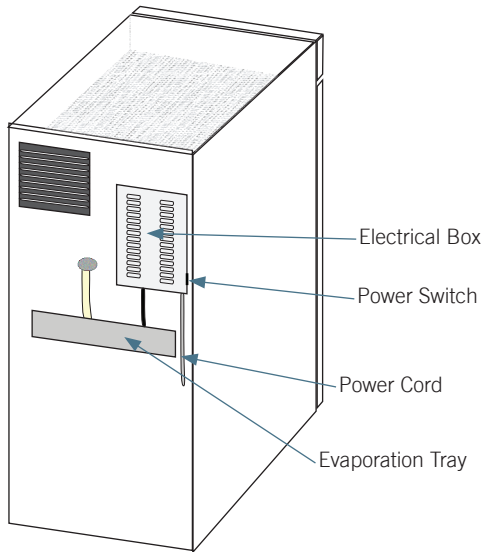
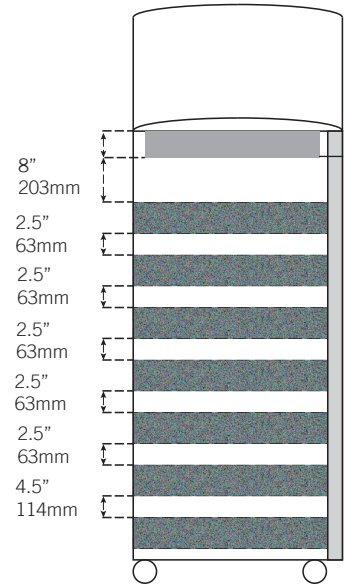
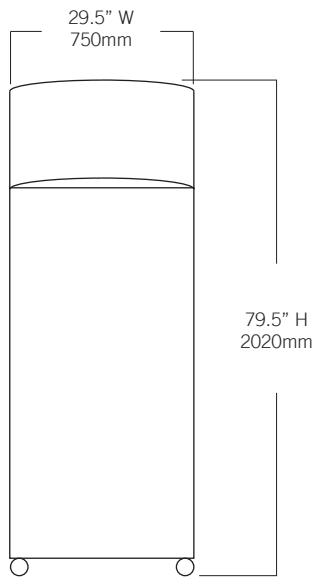

Helmer Scientific | 14400 Bergen Boulevard | Noblesville, IN 46060 | USA
 +1.317.773.9073 | www.helmerinc.com



© 2016-2017 Helmer Inc. All rights reserved. 380298-1/E 5/17
 All trademarks are the property of Helmer Scientific. Specifications subject to change.