

Model

Horizon Series™ HPF120 Upright Plasma Freezer

Specifications

Application, Rating and Electrical Data		Controller	
Application	Storage of blood and other medical and scientific products	Interface	LED digital display, °C or °F
Storage Volume	20.2 cu ft (572 L)	Power Switch	On/Off with circuit breaker
Storage Capacity	360 (plasma boxes)	Controller Type	Microprocessor-based controller with alarm / monitor
Temperature Range	-15° to -30°C	Security	Lockable door, optional keypad access
Electrical Power	115V 60Hz 208/230V 60Hz 230V 50Hz	Control Sensor	RTD
Maximum Current	8.5 FLA / 4.6 FLA / 4.1 FLA	High / Low Alarms	Fully adjustable
Building Supply Rating	15 amp dedicated ground circuit	Door Ajar Alarm	Yes
Power Plug / Power Cord Length	NEMA 5-15 hospital grade plug (115V) NEMA 6-15 hospital grade plug (208/230V 60Hz) CEE 7/7 plug (230V 50Hz) 8-10 ft (2439-3048 mm)	Power Failure Alarm	Yes
Certification / Agency Listing	QPS (Certified to UL and CSA Standards)	Min/Max Display and Reset	Yes
Indoor/Outdoor Use	Indoor use only	Battery Back-up	9-volt non-rechargeable
Application Environment	Non-corrosive, non-flammable, non-explosive, 15°C to 32°C (59°F to 90°F)	Dimensions and Construction	
Refrigeration System		Interior (w x h x d)	24.75 x 58.25 x 24.25 in 629 x 1480 x 616 mm
Refrigeration System	Forced-air circulation	Exterior (w x h x d)	29.5 x 80 x 29.5 in 750 x 2032 x 750 mm
Compressor / Number	1.25 HP hermetic / 1	Overall Exterior (w x h x d) (Includes door handle, electrical panel, and evaporation tray)	30.75 x 80 x 32.5 in 782 x 2032 x 826 mm
Condenser Type / Number	Air-cooled fin and tube / 1	Insulation	Minimum of 2" (51mm) non-CFC foamed urethane insulation
Expansion Device	TXV valve	Exterior / Interior Finish	Bacteria-resistant powder coating
Evaporator Type	Air-cooled fin and tube	Doors	1, Solid
Defrost Method	Automatic, programmable	Access Ports	Top for external monitoring probe(s)
Refrigerant Charge	R404A Non-CFC	Perimeter Heater	Mullion Electric Heater
Performance Data		Interior Storage / Capacity	8 stainless steel drawers 21.5 x 20.75 in (547 x 528 mm) 100 lb (46 kg) max capacity / drawer
Uniformity	+/-2°C at -30°C Setpoint	Casters	Standard / swivel locking
Warranty		Integrated Access Control	Optional - Electromagnetic lock via digital keypad
Standard (US/Canada)	3 years compressor, 2 years parts, 1 year labor	Net Weight	502 lb (228 kg)
Outside US/Canada	Consult your local representative	Shipping Weight	595 lb (270 kg)
		Clearance Requirements	Minimum of 8" (203mm) above and 3" (76mm) behind unit.
		Options / Accessories	Floor & Wall Bracket Kit, Remote Alarms, Leveling Feet, Stainless Steel Interior, Remote Lock Adapter Kit, Extended Warranty



Technical Data Sheet

Plasma Freezer

Horizon Series™ HPF120

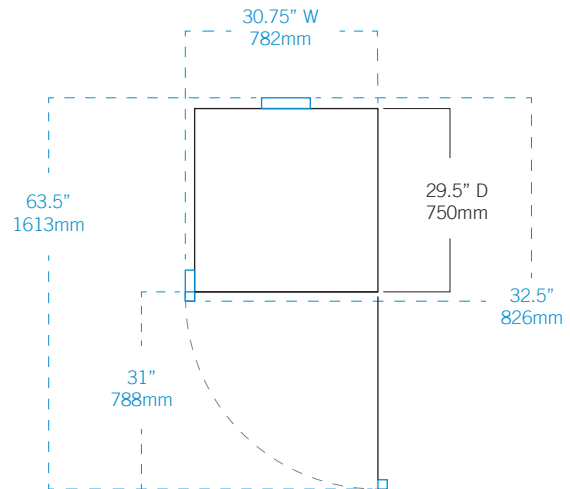
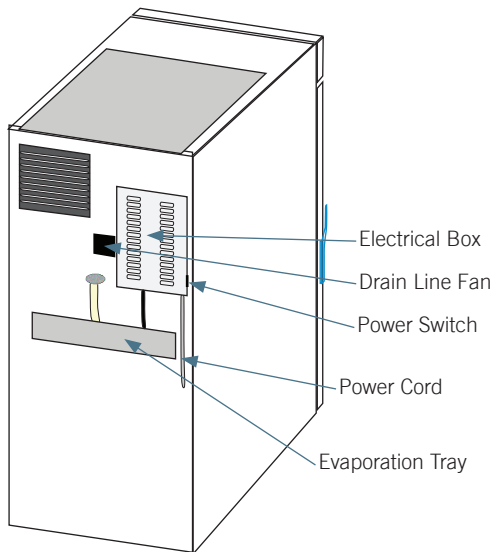
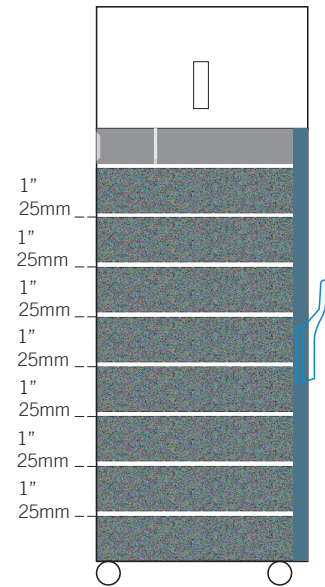
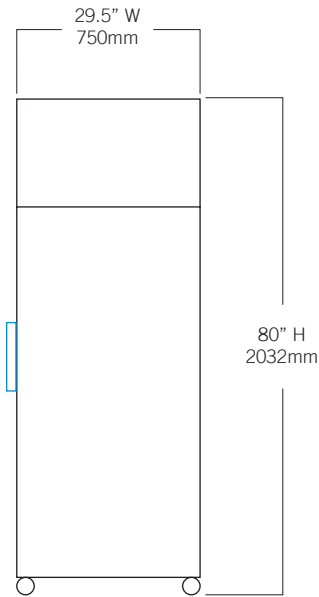

Helmer Scientific | 14400 Bergen Boulevard | Noblesville, IN 46060 | USA
 +1.317.773.9073 | www.helmerinc.com



© 2016, © 2018 Helmer Inc. All rights reserved. 380356-1/F 1/18
 All trademarks are the property of Helmer Scientific. Specifications subject to change.