

Model

Horizon Series™ HLR256 Upright Laboratory Refrigerator

Specifications

Application, Rating and Electrical Data		Controller	
Application	Storage of medical and scientific products	Interface	LED digital display, °C or °F
Storage Volume	56 cu ft (1586 L)	Power Switch	On/Off - All Circuit breaker - 230V only
Temperature Range	2° to 10°C	Controller Type	Microprocessor-based controller with alarm/ monitor
Electrical Power	115V 60Hz 230V 50Hz 230V 60Hz	Security	Lockable door
Maximum Current	11.5 FLA / 6.0 FLA / 6.0 FLA	Control Sensor	RTD
Building Supply Rating	15 amp dedicated ground circuit	High / Low Alarms	Fully adjustable
Power Plug / Power Cord Length	NEMA 5-15 hospital grade plug (115V) CEE 7/7 plug (230V 50Hz) NEMA 6-15 hospital grade plug (230V 60Hz) 8-10 ft (2439-3048 mm)	Door Ajar Alarm	Yes
Certification / Agency Listing	QPS (Certified to UL and CSA Standards) ENERGY STAR® certified (115V)	Power Failure Alarm	Yes
Indoor/Outdoor Use	Indoor use only	Min/Max Display and Reset	Yes
Application Environment	Non-corrosive, non-flammable, non-explosive, 15°C to 32°C (59°F to 90°F)	Battery Back-up	9-volt non-rechargeable
Refrigeration System		Dimensions and Construction	
Refrigeration System	Forced-air circulation	Interior (w x h x d)	55 x 58.25 x 30.25 in 1397 x 1480 x 769 mm
Compressor / Number	.5 HP hermetic / 1	Exterior (w x h x d)	59.25 x 78.75 x 35.5 in 1505 x 2001 x 902 mm
Condenser Type / Number	Air-cooled fin and tube / 1	Overall Exterior (w x h x d) (Includes door handles, electrical panel, and evaporation tray)	59.25 x 78.75 x 38.5 in 1505 x 2001 x 978 mm
Expansion Device	Cap tube	Insulation	Minimum of 2" (51mm) non-CFC foamed urethane insulation
Evaporator Type	Air-cooled fin and tube	Exterior / Interior Finish	Bacteria-resistant powder coating
Defrost Method	Automatic	Doors	2, Dual-pane glass
Refrigerant Charge	R134A Non-CFC	Access Ports	Sidewall with interior and exterior plugs Top for external monitoring probe(s)
Performance Data		Interior Storage / Capacity	8 epoxy coated shelves 22 x 29 in (559 x 737 mm) 100 lb (46 kg) max capacity / shelf
Uniformity	+/-1.5°C at 4°C Setpoint	Lighting	Adjustable LED on/off switch
Warranty		Casters	Standard / swivel locking
Rel.i™ (US/Canada)	5 years compressor, 2 years parts, 1 year labor	Net Weight	728 lb (331 kg)
Outside US/Canada	Consult your local representative	Shipping Weight	858 lb (390 kg)
		Clearance Requirements	Minimum of 8" (203mm) above and 3" (76mm) behind unit.
		Options / Accessories	Chart Recorder, Floor & Wall Bracket Kit, Remote Alarms, Leveling Feet, Stainless Steel Interior, Extended Warranty



Technical Data Sheet

Laboratory Refrigerator

Horizon Series™ HLR256

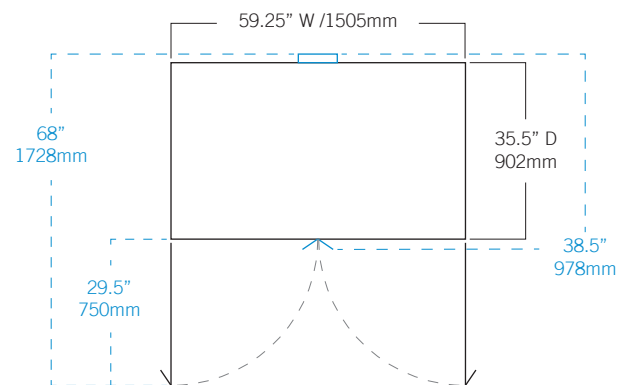
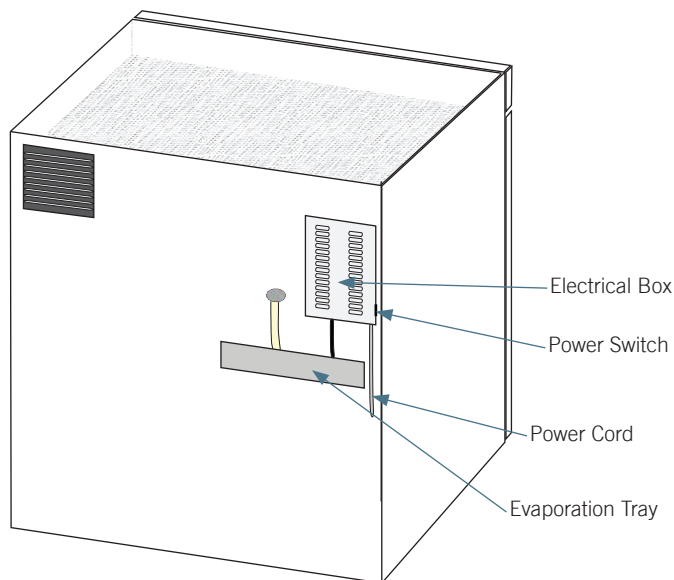
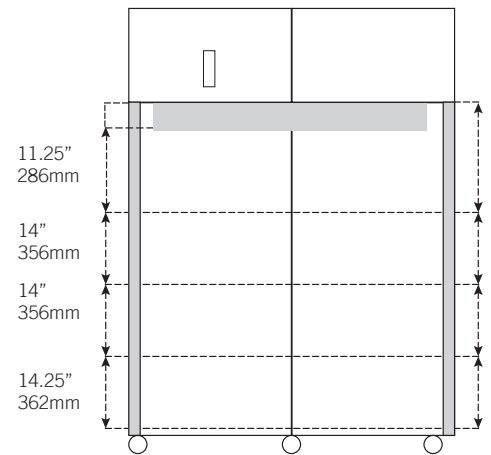
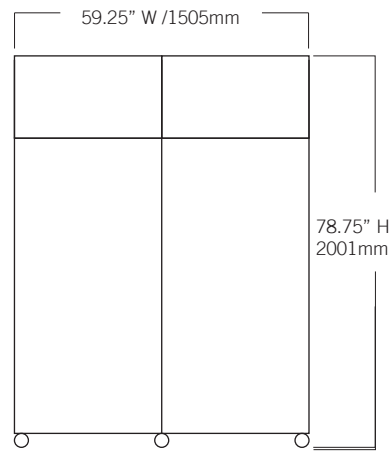

Helmer Scientific | 14400 Bergen Boulevard | Noblesville, IN 46060 | USA
+1.317.773.9073 | www.helmerinc.com



© 2015-2017 Helmer Inc. All rights reserved. 380325-1/E 5/17
All trademarks are the property of Helmer Scientific. Specifications subject to change.