

Model

Horizon Series™ HB111 Upright Blood Bank Refrigerator

Specifications

Application, Rating and Electrical Data		Controller	
Application	Storage of blood and other medical and scientific products	Interface	LED digital display, °C or °F
Storage Volume	11.5 cu ft (326 L)	Power Switch	On/Off - All Circuit breaker - 230V only
Storage Capacity	165 (450 ml bags)	Controller Type	Microprocessor-based controller with alarm/ monitor
Temperature Range	2° to 10°C	Security	Lockable door, optional keypad access
Electrical Power	115V 60Hz 230V 50Hz 230V 60Hz	Control Sensor	RTD
Maximum Current	7 FLA / 3.5 FLA / 3.5 FLA	High / Low Alarms	Fully adjustable
Building Supply Rating	15 amp dedicated ground circuit	Door Ajar Alarm	Yes
Power Plug / Power Cord Length	NEMA 5-15 hospital grade plug (115V) CEE 7/7 plug (230V 50Hz) NEMA 6-15 hospital grade plug (230V 60Hz) 8-10 ft (2439-3048 mm)	Power Failure Alarm	Yes
Certification / Agency Listing	QPS (Certified to UL and CSA Standards)	Min/Max Display and Reset	Yes
Indoor/Outdoor Use	Indoor use only	Battery Back-up	9-volt non-rechargeable
Application Environment	Non-corrosive, non-flammable, non-explosive, 15°C to 32°C (59°F to 90°F)	Dimensions and Construction	
Refrigeration System		Interior (w x h x d)	20 x 49.5 x 20 in 508 x 1258 x 508 mm
Refrigeration System	Forced-air circulation	Exterior (w x h x d)	24.25 x 70.5 x 24.5 in 616 x 1791 x 623 mm
Compressor / Number	.25 HP hermetic / 1	Overall Exterior (w x h x d) (Includes door handle, electrical panel, and evaporation tray)	24.25 x 70.5 x 28.25 in 616 x 1791 x 718 mm
Condenser Type / Number	Air-cooled fin and tube / 1	Insulation	Minimum of 2" (51mm) non-CFC foamed urethane insulation
Expansion Device	Cap tube	Exterior / Interior Finish	Bacteria-resistant powder coating
Evaporator Type	Air-cooled fin and tube	Doors	1, Dual-pane glass
Defrost Method	Automatic	Access Ports	Top for external monitoring probe(s)
Refrigerant Charge	R134A Non-CFC	Interior Storage / Capacity	5 stainless steel drawers 16.75 x 17 in (426 x 432 mm) 100 lb (46 kg) max capacity / drawer
Performance Data		Lighting	Adjustable LED on/off switch
Uniformity	+/-1°C at 4°C Setpoint	Casters	Standard / swivel locking
Warranty		Integrated Access Control	Optional - Electromagnetic lock via digital keypad
Rel.i™ (US/Canada)	5 years compressor, 2 years parts, 1 year labor	Net Weight	345 lb (157 kg)
Outside US/Canada	Consult your local representative	Shipping Weight	427 lb (194 kg)
		Clearance Requirements	Minimum of 8" (203mm) above and 3" (76mm) behind unit.
		Options / Accessories	Floor & Wall Bracket Kit, Remote Alarms, Leveling Feet, Stainless Steel Interior, Remote Lock Adapter Kit, Extended Warranty



Technical Data Sheet

Blood Bank Refrigerator

Horizon Series™ HB111

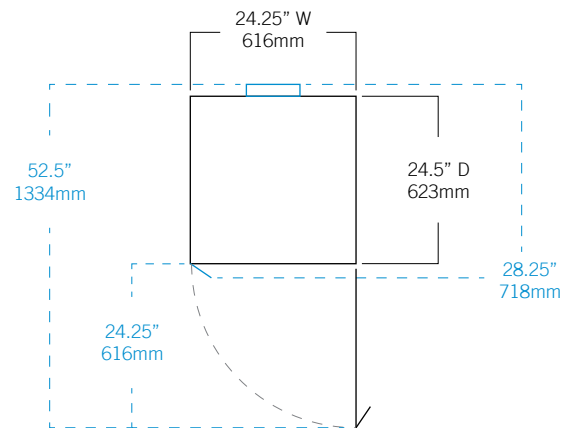
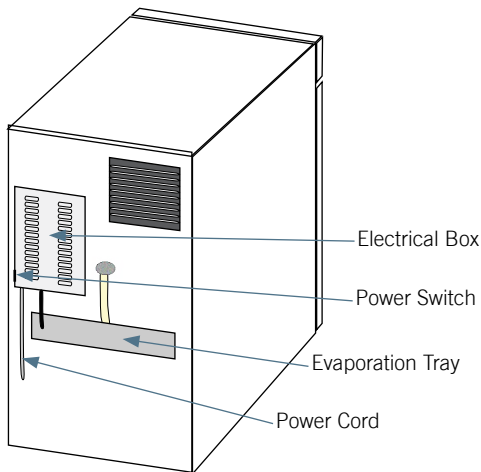
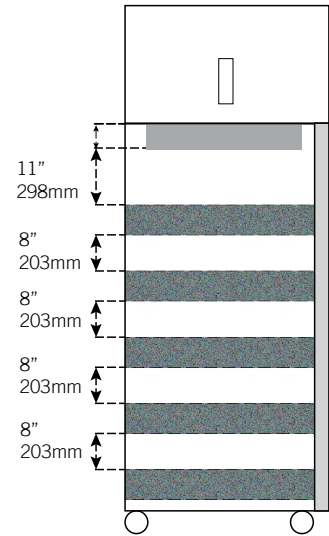
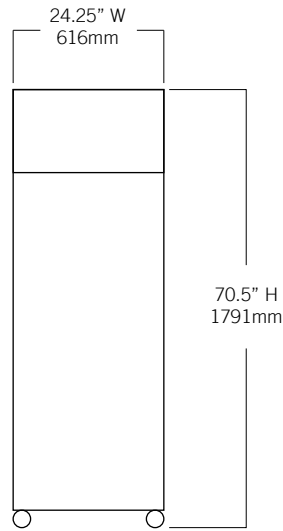

Helmer Scientific | 14400 Bergen Boulevard | Noblesville, IN 46060 | USA
+1.317.773.9073 | www.helmerinc.com

