

## Model

### i.Series® iUF124 Upright Ultra-Low Temperature Freezer

## Specifications

#### Application, Rating and Electrical Data

Application	Storage of biological samples
Storage Volume	24cf (680L)
Storage Capacity	480 standard 2" (51mm) boxes
Temperature Range	-50°C to -86°C @ 32°C (90°F) Ambient
Electrical Power	208/230V 60Hz, 1 Phase
Maximum Current	11 FLA
Auto-Voltage Safeguard	Optional boost system
Building Supply Rating	15 amp dedicated ground circuit
Power Plug / Power Cord Length	NEMA 6-15 plug, 7.5ft (2286mm)
Certification / Agency Listing	QPS
Sound Pressure Level (dBA)	<70 dBA
Indoor/Outdoor Use	Indoor use only
Application Environment	Non-corrosive, non-flammable, non-explosive, 15°C to 32°C (59°F to 90°F)
Lifetime of Product	10 years

#### Refrigeration System

Refrigeration System	Two Stage Cascade System
Compressor / Number	1.5 HP hermetic / 2
Condenser Type / Number	Air-cooled fin and tube / 1
Expansion Device	TXV valve - high stage Cap tube - low stage
Evaporator Type	Split, cold wall
Defrost Method	Manual
Refrigerant Charge	R601 natural refrigerant - low stage R508B nonflammable CFC/HCFC-free - low stage R404A nonflammable CFC/HCFC-free - high stage

#### Performance Data

Energy Consumption	19 kWhr/day at -80°C Setpoint
Uniformity	+/-5°C at -80°C Setpoint

#### Warranty

Rel.i™ (US/Canada)	5 years compressor, 2 years parts and labor
Outside US/Canada	Consult your local representative

#### Controller

Interface	i.C <sup>3</sup> ®, eye-level, color touchscreen
Power Switch	On/Off with circuit breaker
Controller Type	Microprocessor with touchscreen input and display. Includes USB hub for data retrieval.
Security	Lockable door, PIN access control, password setpoints, padlock hasp
Compressor Safeguard	High ambient temperature warning, compressor and condenser over-temperature alarms
Control Sensor	RTD (Platinum) (1 ea)
Communication Ports	(1) RS232 Port (rear) and (1) USB Port (side of door-mounted user interface)
Warm / Cold Alarms	Fully adjustable
Event Log	All alarms, door openings, download via USB
Temperature Log	60 days, download via USB
Access Log	60 days, download via USB
Battery Back-up	20 hour display and alarm battery back-up for i.C <sup>3</sup> ® touchscreen (12V, lead acid battery)

#### Dimensions and Construction

Interior (w x h x d) in (mm)	34.4 x 49.5 x 23.3 (874 x 1257 x 592)
Exterior (w x h x d) in (mm)	45.1 x 78.2 x 34.8 (1146 x 1986 x 884)
Exterior (w x h x d) in (mm) (Inc. handle, casters, hinges)	48.4 x 78.2 x 37.5 (1229 x 1986 x 953) Fits through standard 36" (914mm) doorway
Insulation	5" (127mm) Ecomate®, non HFC
Door	1, solid
Access Ports	2, external
Perimeter Heater	Hot gas loop
Compartments & Inner Doors Shelves / Capacity	4 3 adjustable stainless steel / 160 lb (73 kg) max. cap.
Casters / Legs	Standard / swivel, locking plus leveling legs
Net Weight	704 lb (319 kg)
Shipping Weight	806 lb (365 kg)
Options / Accessories	Chart Recorder, LN2 and CO2 back-up systems, -70°C factory preset, voltage boost system
Clearance Requirements	Allow 4" (102mm) behind unit Allow 8" (203mm) above unit

# Technical Data Sheet

## -86°C Ultra-Low Freezer

i.Series® iUF124

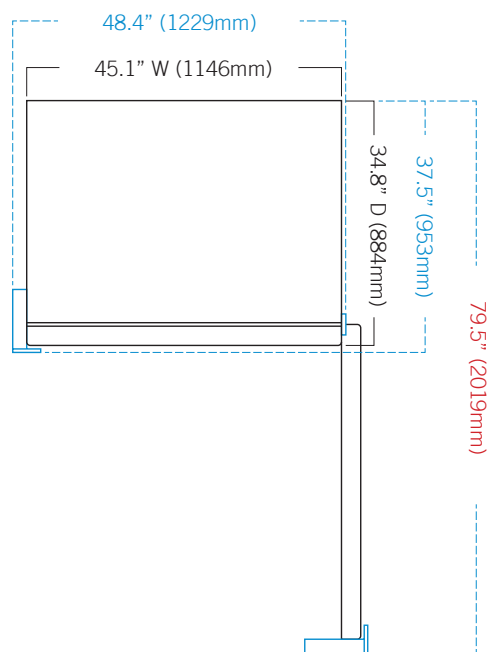
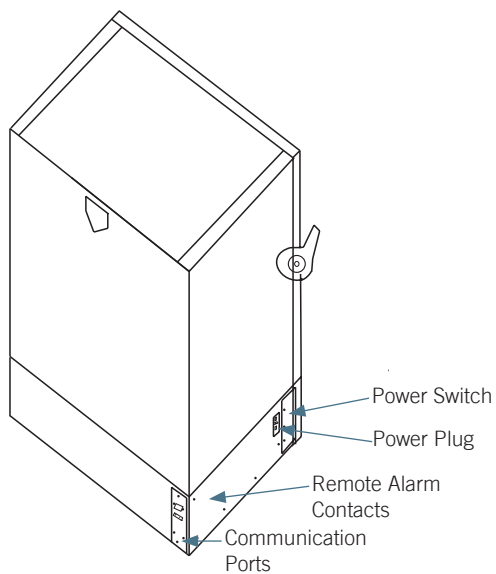
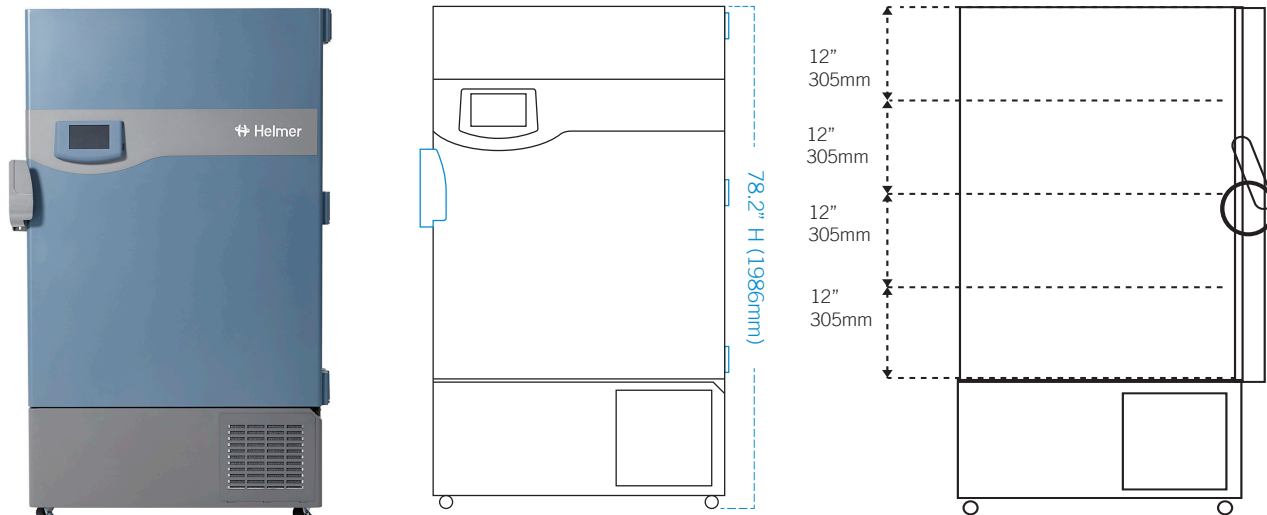

Helmer Scientific | 14400 Bergen Boulevard | Noblesville, IN 46060 | USA  
+1.317.773.9073 | www.helmerinc.com



© 2014, © 2016, © 2018 Helmer Inc. All rights reserved. 380360-1/D 1/18  
All trademarks are the property of Helmer Scientific. Specifications subject to change.