

Model

Horizon Series™ HLF125 Upright Laboratory Freezer

Specifications

Application, Rating and Electrical Data

Application	Storage of medical and scientific products
Storage Volume	25.2 cu ft (714 L)
Temperature Range	-15° to -30°C
Electrical Power	115V 60Hz 208/230V 60Hz 230V 50Hz
Maximum Current	8.5 FLA / 4.6 FLA / 4.1 FLA
Building Supply Rating	15 amp dedicated ground circuit
Power Plug / Power Cord Length	NEMA 5-15 hospital grade plug (115V) NEMA 6-15 hospital grade plug (208/230V 60Hz) CEE 7/7 plug (230V 50Hz) 8-10 ft (2439-3048 mm)
Certification / Agency Listing	QPS (Certified to UL and CSA Standards)
Indoor/Outdoor Use	Indoor use only
Application Environment	Non-corrosive, non-flammable, non-explosive, 15°C to 32°C (59°F to 90°F)

Refrigeration System

Refrigeration System	Forced-air circulation
Compressor / Number	1.25 HP hermetic / 1
Condenser Type / Number	Air-cooled fin and tube / 1
Expansion Device	TXV valve
Evaporator Type	Air-cooled fin and tube
Defrost Method	Automatic, programmable
Refrigerant Charge	R404A Non-CFC

Performance Data

Uniformity	+/-2°C at -30°C Setpoint
------------	--------------------------

Warranty

Standard (US/Canada)	3 years compressor, 2 years parts, 1 year labor
Outside US/Canada	Consult your local representative

Controller

Interface	LED digital display, °C or °F
Power Switch	On/Off with circuit breaker
Controller Type	Microprocessor-based controller with alarm/ monitor
Security	Lockable door, optional keypad access
Control Sensor	RTD
High / Low Alarms	Fully adjustable
Door Ajar Alarm	Yes
Power Failure Alarm	Yes
Min/Max Display and Reset	Yes
Battery Back-up	9-volt non-rechargeable

Dimensions and Construction

Interior (w x h x d)	24.75 x 58.25 x 30.25 in 629 x 1480 x 769 mm
Exterior (w x h x d)	29.5 x 80 x 35.5 in 750 x 2013 x 902 mm
Overall Exterior (w x h x d) (Includes door handle, electrical panel, and evaporation tray)	30.75 x 80 x 38.5 in 782 x 2032 x 978 mm
Insulation	Minimum of 2" (51mm) non-CFC foamed urethane insulation
Exterior / Interior Finish	Bacteria-resistant powder coating
Doors	1, Solid
Access Ports	Top for external monitoring probe(s)
Perimeter Heater	Mullion Electric Heater
Interior Storage / Capacity	4 epoxy coated shelves 22 x 29 in (559 x 737 mm) 100 lb (46 kg) max capacity / shelf
Casters	Standard / swivel locking
Integrated Access Control	Optional - Electromagnetic lock via digital keypad
Net Weight	478 lb (217 kg)
Shipping Weight	571 lb (260 kg)
Clearance Requirements	Minimum of 8" (203mm) above and 3" (76mm) behind unit.
Options / Accessories	Chart Recorder, Floor & Wall Bracket Kit, Remote Alarms, Leveling Feet, Stainless Steel Interior, Remote Lock Adapter Kit, Extended Warranty



Technical Data Sheet

Laboratory Freezer

Horizon Series™ HLF125

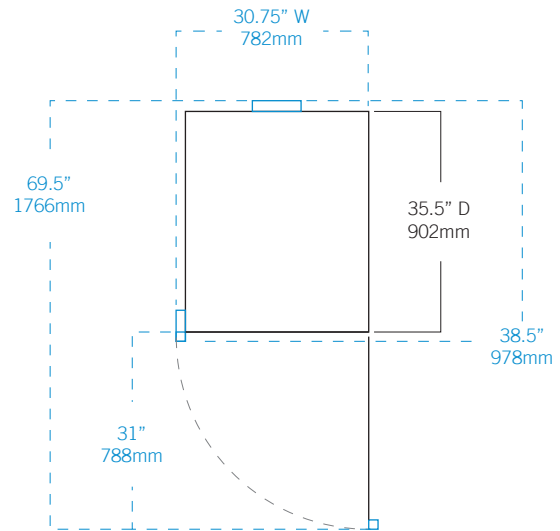
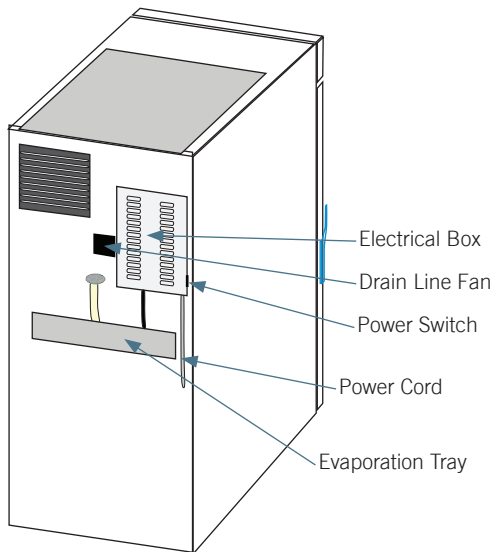
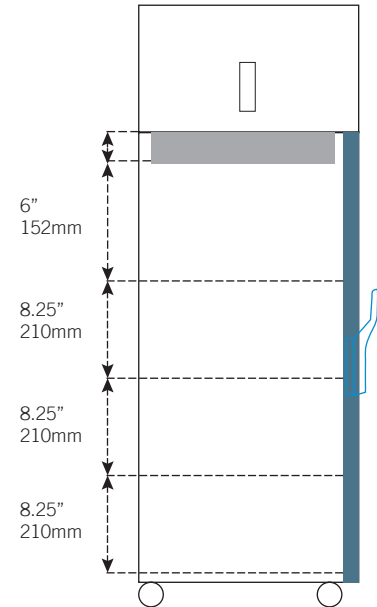
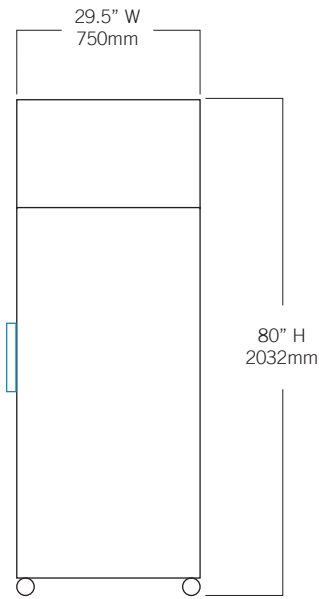

Helmer Scientific | 14400 Bergen Boulevard | Noblesville, IN 46060 | USA
 +1.317.773.9073 | www.helmerinc.com



© 2016, © 2018 Helmer Inc. All rights reserved. 380349-1/F 1/18
 All trademarks are the property of Helmer Scientific. Specifications subject to change.