

Application, Rating, & Electrical Data	
Application	High-performance storage of medical and scientific products
Storage Volume	5.3 cu ft (150 L)
Temperature Range	+2°C to +10°C
Set Point	4°C
Electrical Power	115V 60Hz 220-240V 50/60Hz
Maximum Current	1.4A 0.85A
Building Supply Rating	15A dedicated ground circuit
Power Plug/Power Cord Length	NEMA 5-15 hospital-grade 115V 8 to 10 ft (2.4-3.0m) CEE (Schuko) 7/7 230V 50Hz, 8 to 10 ft (2.4-3.0m) NEMA 6-15 hospital-grade 230V 60Hz, 8 to 10 ft (2.4-3.0m)
Certification/Agency Listing	QPS (Certified to UL and CSA Standards) IEC/UL61010-2-011 (Dec 2016)
Energy Star	Yes
ADA Compliant	Yes, fits under standard 36" high ADA compliant countertop
Indoor/Outdoor Use	Indoor Use Only
Application Environment	Non-corrosive, non-flammable, non-explosive
Ambient Operating Temperature	15°C to 32°C 59°F to 90°F
Refrigeration	
Refrigeration System	VCC compressor-based, forced-air hydrocarbon
Compressor	Hermetic, variable speed (VCC). Rated speed range: 1300-4000 rpm
Condenser Type	Air-cooled fin and tube, sealed
Expansion Device	Cap tube
Evaporator Type	Direct expansion with forced-air fin and tube
Defrost Method	Automatic
Refrigerant	R600a, Isobutane, EPA SNAP compliant
Controller / Configuration Settings	
User Interface	LED digital display, °C or °F
Power Switch	On/Off
Controller Type	Microprocessor with alarm/monitor
Security	Lockable door, optional keypad access
Control Sensor	RTD, stainless steel
Communication Port	Remote alarm contacts
Power Failure Alarm	Yes
High/Low Alarms	Yes, fully adjustable
Door Ajar Alarm	Yes, fully adjustable
Min/Max Temperature	Yes, display and reset
Temperature Monitoring Ballast	Yes, 4 oz bottle with screw cap, solid monitoring ballast optional
Battery Back-up	Yes, 9 volt, non-rechargeable lithium

Performance Characteristics (normal operating conditions)	
Uniformity °C	+/-1.0
Recovery to 7°C after 3 min door opening min	11
Stability °C	0.82
Energy Consumption kWh/day	1.2
Noise emission dB	42
Heat rejection/emission BTU/hr	460
Pull-down time min	36

All performance data from 5 cu ft refrigerator, 24.8 ambient, 4.0°C

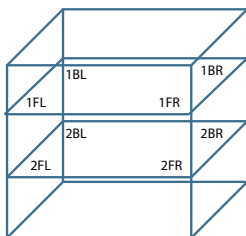
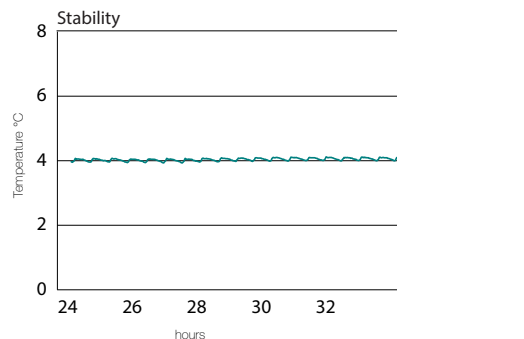
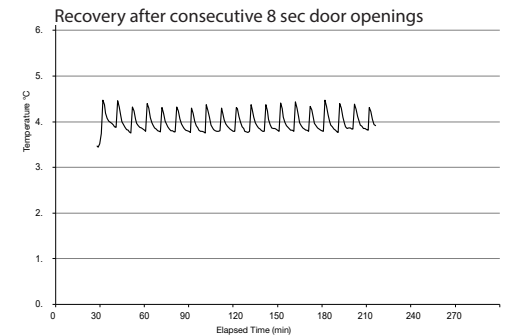
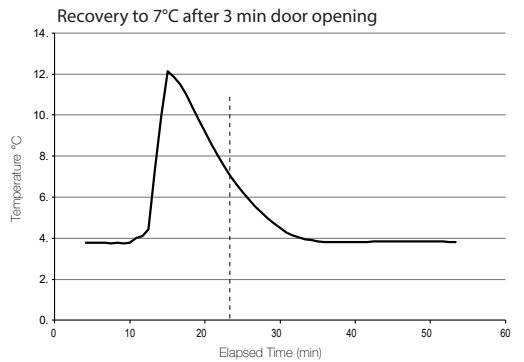
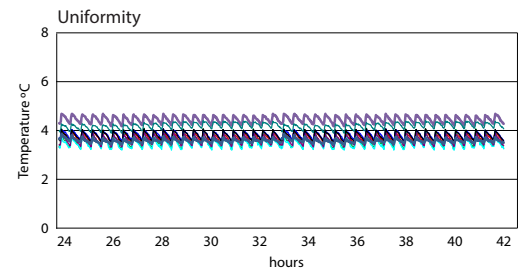

Location of test probes

Typical Temperature Map

5 cu ft. Temperature Map (°C)

	1FL	1FR	1BL	1BR	2FL	2FR	2BL	2BR
Avg	4.0	3.9	3.6	3.5	4.3	3.9	4.4	3.8
Max	4.5	4.3	4.2	4.2	4.5	4.3	4.7	4.3
Min	3.7	3.5	3.2	3.1	4.0	3.5	4.1	3.4

Dimensions and Construction	
Interior (w x h x d)	19.5 x 19.9 x 22.8 in 496 x 505 x 580 mm
Exterior (w x h x d)	24 x 31.5 x 26.7 in 610 x 796 x 678 mm
Overall Exterior (w x h x d)	24 x 31.9 x 28.1 in 610 x 798 x 678 mm (Includes leveling feet and door handle)
Insulation	Sustainable, US EPA, SNAP and GRAS approved foam
Exterior/Interior Finish	Bacteria-resistant powder-coating
Door	Solid, field-reversible
Access Port	Rear access port
Interior Storage	2 ventilated shelves, adjustable 17.9 x 21.3 in 454 x 541 mm, 100 lb 46kg max capacity/shelf
Leveling Feet	Yes, adjustable
Integrated Access Control	Optional - electromagnetic-lock via Horizon PIN
Net Weight	174 lb 79 kg
Shipping Weight	235 lb 107kg
Clearance Requirements	Minimum 3 in (76mm) behind unit for clearance and feature access
Options Accessories	Glass door, LED light, Integrated access control, Stainless steel exterior/interior, TCR2 chart recorder, Swivel, locking casters, Solid ballast, Remote alarms, Stacking kit, Floor and Wall bracket kit, Storage trays, Pedestal, Locking drawer, Certificate of Calibration, Temperature Validation, Validation Guides (IQ/OQ), Extended Warranty

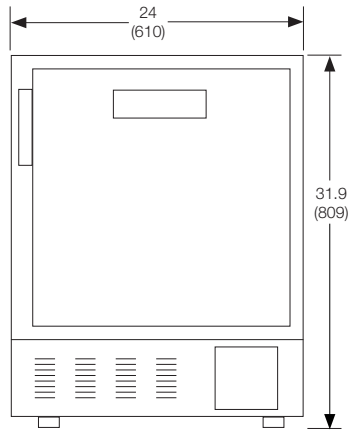

FRONT VIEW

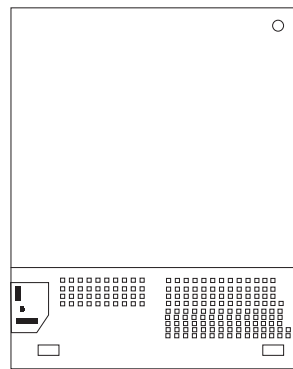

BACK VIEW

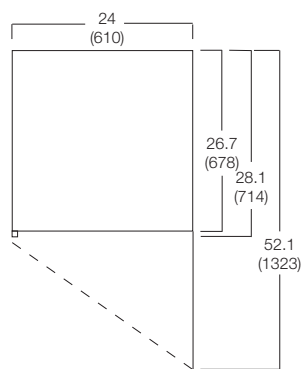

TOP VIEW

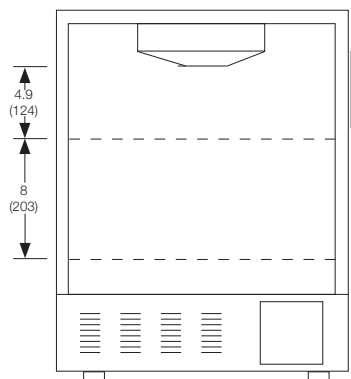

INTERIOR VERTICAL SPACING